

SILENCER SHEETS

AL ACOUSTICAL LOUVER

DESCRIPTION

Vibro-Acoustics' Acoustical Louvers are designed to allow air-flow through ventilation openings while reducing the radiation of noise. They use acoustic grade glass fiber as the principle sound-absorbing mechanism. Acoustical splitters, sometimes called vanes or splitter vanes, are used for mid to higher frequency attenuation. Perforated metal protects the glass fiber from erosion by the airflow.

The splitters vary in quantity and thickness, and air passages also vary in width. They are aerodynamically shaped to minimize pressure drop. Lips are designed into the splitters to protect against weather elements.

APPLICATION

- ◆ where there is not enough space to fit in standard length or short silencers (see SAS 9)
- ◆ in ventilation openings for mechanical rooms, cooling towers, screen walls, enclosures for diesels, etc. (see SAS 14)
- ◆ in substitution of architectural louvers where aesthetics is not of primary concern (e.g. some Water Treatment and Power Plants)

FEATURES AND BENEFITS

- ◆ available in any cross-sectional dimensions to "fit-the-opening"
- ◆ modular unit sizes to fit openings without using transitions or large blank-off sections
- ◆ standard depth 12"; also other depths available
- ◆ 1"x1" heavy wire mesh birdscreen (usually on inconspicuous side)
- ◆ can be selected to suit the acoustic, space, or energy-cost requirements
- ◆ construction quality and aerodynamic design optimized to give reliable performance, best acoustics, lowest pressure drop and lowest overall cost

CAUTIONS / WHEN NOT TO USE AL SILENCERS

- ◆ when more attenuation is required see Short Silencers (SS13) or Fan Silencers (SS10 and SS11)

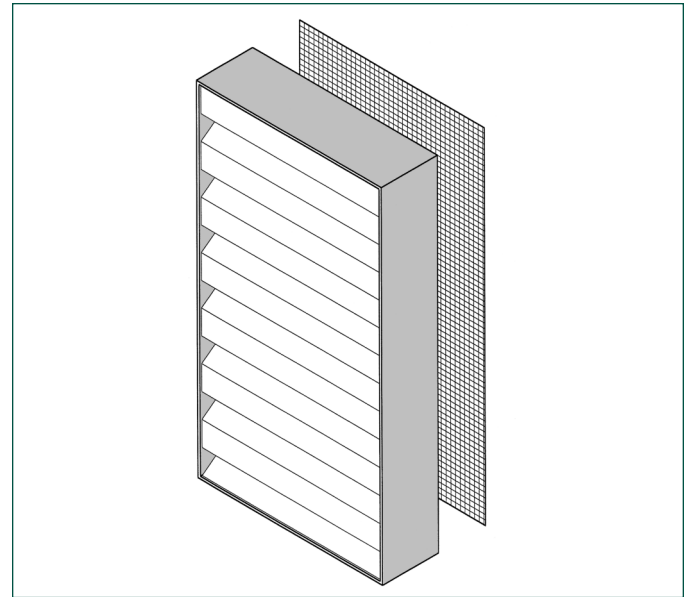

SILENCER SHEETS

TESTING

Vibro-Acoustics' 4th generation aero-acoustic laboratory was the first laboratory to be NVLAP accredited for the ASTM E-477 silencer test code. NVLAP is administered by the U.S. Dept. of Commerce. See the Corporate/ Laboratory Section.

ACOUSTIC LOUVER SELECTION

Vibro-Acoustics' Acoustical Louvers need to be carefully selected to optimize performance. Call 1-800-565-8401 for custom selections by our application engineers.

STANDARD CONSTRUCTION FEATURES

- ◆ solid galvanized frame
- ◆ aerodynamically shaped galvanized splitters (exposed side: solid; underside: perforated and weather lips built-in both ends)
- ◆ splitters filled with acoustic grade glass fiber under minimum 15% compression
- ◆ 1"x1" heavy wire mesh birdscreen (usually on inconspicuous side)

SPECIAL CONSTRUCTION OPTIONS

- ◆ special materials e.g. stainless steel, aluminum
- ◆ prime coat paint finish
- ◆ media protection: glass fiber cloth, film liner
- ◆ for details of above and more special options see Special Construction Options (pg. 3.33 to pg. 3.37).

TO SPECIFY

See example specification located in the Selection/ Specification section.