

## RD-LV-F1

Rectangular Dissipative  
Low velocity silencer  
(<750 fpm)

How to Specify Example:

32 X 21 RD-LV-F1 X 60  
 ↑ Duct Width    ↑ Duct Height    ↑ Silencer Model    ↑ Silencer Length

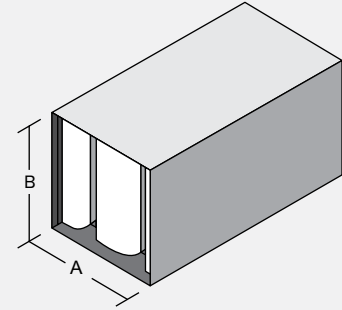

### Insertion Loss (IL)

+ : "forward flow" where noise & airflow move in same direction (e.g. supply side)

- : "reverse flow" where noise & airflow move in opposite directions (e.g. return side)

See [Silencer Selection Instructions](#). DIL above 50dB may be limited due to noise flanking around the silencer or along the duct walls. If more than 50dB DIL is required, contact your local Vibro-Acoustics representative or call **1-800-565-8401**.

Length (in.)	Face Velocity (ft. per min)	Octave Band - Hz/Dynamic Insertion Loss (dB)							
		63	125	250	500	1000	2000	4000	8000
36	- 750	7	11	17	18	21	15	15	13
	0	5	11	17	18	21	18	16	13
	+ 750	5	10	16	17	20	18	16	13
60	- 750	10	15	27	29	34	24	18	16
	0	9	14	26	28	34	25	19	16
	+ 750	8	14	24	27	34	25	20	16
84	- 750	13	19	36	40	47	33	21	18
	0	12	18	35	38	47	32	23	19
	+ 750	11	18	33	37	47	33	23	18
108	- 750	17	23	45	46	55	41	24	21
	0	15	22	44	46	55	38	26	22
	+ 750	13	21	42	46	55	40	27	21

### Pressure Drop (PD)

Pressure drops are reported in accordance with ASTM E477 methods and are based upon **ideal** flow conditions (5 diameters of straight duct on silencer inlet and 10 on outlet). Less than ideal conditions will result in an increase in pressure drop due to System Effects. See [Silencer System Effects Data](#).

Length (in.)	Face Velocity (ft. per min) / Pressure Drop (in.w.g.)						
	250	500	750	1000	1250	1500	1750
36	0.02	0.07	0.15	0.27	0.42	0.61	0.83
60	0.02	0.09	0.20	0.36	0.56	0.80	1.09
84	0.03	0.11	0.25	0.45	0.70	1.00	1.36
108	0.03	0.13	0.30	0.53	0.83	1.20	1.63

Acceptable (0 - 0.35")     Caution (>0.35") Pressure Drop may be too high for certain applications

### Generated Noise (GN)

@ 5 sq.ft. face area

Length (in.)	Face Velocity (ft. per min)	Octave Band - Hz/Generated Noise (dB re 10 <sup>-12</sup> watts)							
		63	125	250	500	1K	2K	4K	8K
All	- 750	52	44	40	44	48	46	34	27
	- 500	52	41	38	40	39	32	22	26
	+ 500	54	38	31	29	31	27	21	26
	+ 750	52	43	36	34	38	38	28	26

GN correction chart at right must be used to correct GN to other face areas. →

Face Area (sq.ft.)	2.5	5	10	20	40	80
dB	-3	0	+3	+6	+9	+12

**Cross Section Sizes\***

**"A" dimension (in.)**  
 15-16  
 29-32  
 58-64  
 87-96  
 116-128  
 145-160  
 174-192  
 203-224  
 232-240

**"B" dimension**  
 ANY SIZE

**Approx. weight**  
 6.4 lbs/cu.ft.

See [Rectangular Silencer Cross-Section Dimensions](#) to ensure selection matches ductwork dimensions.

## RD-LV-F2

Rectangular Dissipative  
Low velocity silencer  
(<750 fpm)

How to Specify Example:

27 X 22 RD-LV-F2 X 60  
 ↑ Duct Width    ↑ Duct Height    ↑ Silencer Model    ↑ Silencer Length

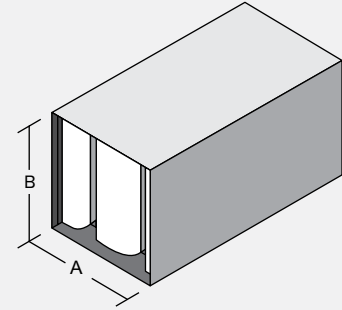

### Insertion Loss (IL)

+ : "forward flow" where noise & airflow move in same direction (e.g. supply side)

- : "reverse flow" where noise & airflow move in opposite directions (e.g. return side)

See [Silencer Selection Instructions](#). DIL above 50dB may be limited due to noise flanking around the silencer or along the duct walls. If more than 50dB DIL is required, contact your local Vibro-Acoustics representative or call **1-800-565-8401**.

Length (in.)	Face Velocity (ft. per min)	Octave Band - Hz/Dynamic Insertion Loss (dB)							
		63	125	250	500	1000	2000	4000	8000
36	- 750	7	10	17	20	22	17	14	12
	0	5	10	17	19	22	18	15	12
	+ 750	5	9	16	18	22	19	15	12
60	- 750	10	15	26	32	36	26	18	14
	0	9	14	25	31	36	27	19	15
	+ 750	8	13	24	30	36	28	20	15
84	- 750	13	19	35	42	50	36	21	17
	0	12	18	34	41	50	36	23	18
	+ 750	11	17	32	40	50	38	24	18
108	- 750	16	23	44	46	55	43	25	19
	0	15	22	42	46	55	43	27	20
	+ 750	13	21	41	46	55	44	28	20

### Pressure Drop (PD)

Pressure drops are reported in accordance with ASTM E477 methods and are based upon **ideal** flow conditions (5 diameters of straight duct on silencer inlet and 10 on outlet). Less than ideal conditions will result in an increase in pressure drop due to System Effects. See [Silencer System Effects Data](#).

Length (in.)	Face Velocity (ft. per min) / Pressure Drop (in.w.g.)						
	250	500	750	1000	1250	1500	1750
36	0.02	0.07	0.15	0.26	0.41	0.59	0.81
60	0.02	0.09	0.20	0.35	0.55	0.79	1.08
84	0.03	0.11	0.24	0.43	0.67	0.97	1.32
108	0.03	0.12	0.28	0.50	0.77	1.11	1.52

Acceptable (0 - 0.35")     Caution (>0.35") Pressure Drop may be too high for certain applications

### Generated Noise (GN)

@ 5 sq.ft. face area

Length (in.)	Face Velocity (ft. per min)	Octave Band - Hz/Generated Noise (dB re 10 <sup>-12</sup> watts)							
		63	125	250	500	1K	2K	4K	8K
All	- 750	51	45	42	46	48	47	34	27
	- 500	51	42	41	41	40	33	22	25
	+ 500	53	38	32	30	31	28	21	25
	+ 750	52	43	37	35	38	39	29	25

GN correction chart at right must be used to correct GN to other face areas. →

Face Area (sq.ft.)	2.5	5	10	20	40	80
dB	-3	0	+3	+6	+9	+12

**Cross Section Sizes\***

**"A" dimension (in.)**  
 14  
 27-28  
 54-57  
 81-86  
 108-115  
 135-144  
 162-173  
 189-202  
 216-231

**"B" dimension**  
 ANY SIZE

**Approx. weight**  
 6.4 lbs/cu.ft.

See [Rectangular Silencer Cross-Section Dimensions](#) to ensure selection matches ductwork dimensions.

## RD-LV-F3

Rectangular Dissipative  
Low velocity silencer  
(<750 fpm)

How to Specify Example:

25 X 21 RD-LV-F3 X 60  
 ↑ Duct Width    ↑ Duct Height    ↑ Silencer Model    ↑ Silencer Length

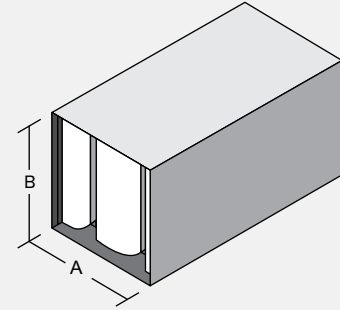

### Insertion Loss (IL)

+ : "forward flow" where noise & airflow move in same direction (e.g. supply side)

- : "reverse flow" where noise & airflow move in opposite directions (e.g. return side)

See [Silencer Selection Instructions](#). DIL above 50dB may be limited due to noise flanking around the silencer or along the duct walls. If more than 50dB DIL is required, contact your local Vibro-Acoustics representative or call **1-800-565-8401**.

Length (in.)	Face Velocity (ft. per min)	Octave Band - Hz/Dynamic Insertion Loss (dB)							
		63	125	250	500	1000	2000	4000	8000
36	- 750	7	10	17	21	23	18	13	11
	0	5	9	16	21	23	19	14	11
	+ 750	5	8	15	20	23	19	14	12
60	- 750	9	15	25	35	38	28	17	13
	0	8	14	24	34	38	29	19	14
	+ 750	8	13	23	33	38	30	20	14
84	- 750	13	19	35	44	55	39	22	15
	0	12	18	33	44	55	41	24	17
	+ 750	11	17	32	43	55	43	25	17
108	- 750	16	24	43	46	55	45	25	18
	0	15	22	41	46	55	47	28	19
	+ 750	13	21	39	46	55	48	29	20

### Pressure Drop (PD)

Pressure drops are reported in accordance with ASTM E477 methods and are based upon **ideal** flow conditions (5 diameters of straight duct on silencer inlet and 10 on outlet). Less than ideal conditions will result in an increase in pressure drop due to System Effects. See [Silencer System Effects Data](#).

Length (in.)	Face Velocity (ft. per min) / Pressure Drop (in.w.g.)						
	250	500	750	1000	1250	1500	1750
36	0.02	0.06	0.14	0.26	0.40	0.58	0.79
60	0.02	0.09	0.19	0.35	0.54	0.78	1.06
84	0.03	0.10	0.23	0.42	0.65	0.93	1.27
108	0.03	0.11	0.26	0.46	0.71	1.03	1.40

Acceptable (0 - 0.35")     Caution (>0.35") Pressure Drop may be too high for certain applications

### Generated Noise (GN)

@ 5 sq.ft. face area

Length (in.)	Face Velocity (ft. per min)	Octave Band - Hz/Generated Noise (dB re 10 <sup>-12</sup> watts)							
		63	125	250	500	1K	2K	4K	8K
All	- 750	50	46	44	47	49	47	35	26
	- 500	51	42	43	43	41	35	23	24
	+ 500	51	39	33	31	32	28	21	24
	+ 750	52	44	38	35	39	39	29	25

GN correction chart at right must be used to correct GN to other face areas. →

Face Area (sq.ft.)	2.5	5	10	20	40	80
dB	-3	0	+3	+6	+9	+12

**Cross Section Sizes\***

**"A" dimension (in.)**  
 13  
 25-26  
 50-53  
 75-80  
 100-107  
 125-134  
 150-161  
 175-188  
 200-215  
 225-240

**"B" dimension ANY SIZE**

**Approx. weight 6.6 lbs/cu.ft.**

See [Rectangular Silencer Cross-Section Dimensions](#) to ensure selection matches ductwork dimensions.

## RD-LV-F4

Rectangular Dissipative  
Low velocity silencer  
(<750 fpm)

How to Specify Example:

47 X 22 RD-LV-F4 X 60  
 ↑ Duct Width    ↑ Duct Height    ↑ Silencer Model    ↑ Silencer Length

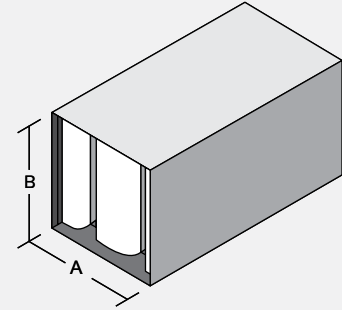

### Insertion Loss (IL)

+ : "forward flow" where noise & airflow move in same direction (e.g. supply side)

- : "reverse flow" where noise & airflow move in opposite directions (e.g. return side)

See [Silencer Selection Instructions](#). DIL above 50dB may be limited due to noise flanking around the silencer or along the duct walls. If more than 50dB DIL is required, contact your local Vibro-Acoustics representative or call **1-800-565-8401**.

Length (in.)	Face Velocity (ft. per min)	Octave Band - Hz/Dynamic Insertion Loss (dB)							
		63	125	250	500	1000	2000	4000	8000
36	- 750	7	9	17	23	24	19	12	10
	0	5	8	16	22	24	19	13	10
	+ 750	5	7	15	21	24	20	14	11
60	- 750	9	14	24	38	40	30	17	12
	0	8	13	23	38	39	32	19	13
	+ 750	8	12	22	36	40	33	20	14
84	- 750	14	19	34	46	55	42	22	14
	0	12	18	32	46	55	46	24	15
	+ 750	11	16	31	45	55	49	26	16
108	- 750	15	24	41	45	55	47	25	17
	0	15	22	39	46	55	51	28	18
	+ 750	13	21	38	46	55	52	30	19

### Pressure Drop (PD)

Pressure drops are reported in accordance with ASTM E477 methods and are based upon **ideal** flow conditions (5 diameters of straight duct on silencer inlet and 10 on outlet). Less than ideal conditions will result in an increase in pressure drop due to System Effects. See [Silencer System Effects Data](#).

Length (in.)	Face Velocity (ft. per min) / Pressure Drop (in.w.g.)						
	250	500	750	1000	1250	1500	1750
36	0.02	0.06	0.14	0.25	0.39	0.56	0.77
60	0.02	0.09	0.19	0.34	0.53	0.77	1.04
84	0.03	0.10	0.23	0.40	0.63	0.90	1.23
108	0.03	0.11	0.24	0.42	0.66	0.95	1.29

Acceptable (0 - 0.35")     Caution (>0.35") Pressure Drop may be too high for certain applications

### Generated Noise (GN)

@ 5 sq.ft. face area

Length (in.)	Face Velocity (ft. per min)	Octave Band - Hz/Generated Noise (dB re 10 <sup>-12</sup> watts)							
		63	125	250	500	1K	2K	4K	8K
All	- 750	49	48	46	49	50	48	35	25
	- 500	51	43	45	44	43	36	23	24
	+ 500	50	39	34	31	32	29	20	23
	+ 750	52	45	39	36	39	40	30	25

GN correction chart at right must be used to correct GN to other face areas. →

Face Area (sq.ft.)	2.5	5	10	20	40	80
dB	-3	0	+3	+6	+9	+12

#### Cross Section Sizes\*

"A" dimension (in.)  
 12  
 23-24  
 46-49  
 69-74  
 92-99  
 115-124  
 138-149  
 161-174  
 184-199  
 207-224  
 230-240

"B" dimension  
 ANY SIZE

Approx. weight  
 6.7 lbs/cu.ft.

See [Rectangular Silencer Cross-Section Dimensions](#) to ensure selection matches ductwork dimensions.

## RD-LV-F5

Rectangular Dissipative  
Low velocity silencer  
(<750 fpm)

How to Specify Example:

**44** X **22** **RD-LV-F5** X **60**  
 ↑        ↑        ↑        ↑  
 Duct Width   Duct Height   Silencer Model   Silencer Length

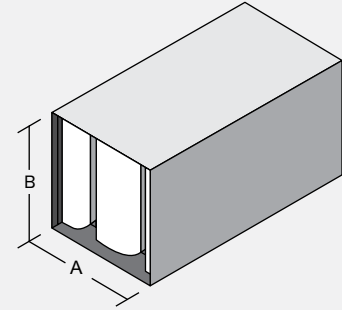

### Insertion Loss (IL)

+ : "forward flow" where noise & airflow move in same direction (e.g. supply side)

- : "reverse flow" where noise & airflow move in opposite directions (e.g. return side)

See [Silencer Selection Instructions](#). DIL above 50dB may be limited due to noise flanking around the silencer or along the duct walls. If more than 50dB DIL is required, contact your local Vibro-Acoustics representative or call **1-800-565-8401**.

Length (in.)	Face Velocity (ft. per min)	Octave Band - Hz/Dynamic Insertion Loss (dB)							
		63	125	250	500	1000	2000	4000	8000
36	- 750	6	8	16	23	27	22	14	10
	0	5	8	15	22	27	21	15	11
	+ 750	4	7	14	21	27	22	15	11
60	- 750	8	14	23	38	42	33	20	13
	0	8	13	22	37	42	36	22	15
	+ 750	8	12	21	36	42	37	23	16
84	- 750	13	19	33	46	55	45	27	16
	0	12	18	31	46	55	49	29	18
	+ 750	11	17	30	45	55	51	31	19
108	- 750	15	24	40	45	55	48	29	19
	0	14	22	38	46	55	53	33	21
	+ 750	13	21	36	46	55	54	35	22

### Pressure Drop (PD)

Pressure drops are reported in accordance with ASTM E477 methods and are based upon **ideal** flow conditions (5 diameters of straight duct on silencer inlet and 10 on outlet). Less than ideal conditions will result in an increase in pressure drop due to System Effects. See [Silencer System Effects Data](#).

Length (in.)	Face Velocity (ft. per min) / Pressure Drop (in.w.g.)						
	250	500	750	1000	1250	1500	1750
36	0.02	0.07	0.15	0.26	0.41	0.59	0.80
60	0.02	0.09	0.21	0.37	0.58	0.83	1.13
84	0.03	0.11	0.24	0.43	0.67	0.96	1.31
108	0.03	0.11	0.25	0.45	0.70	1.00	1.37

Acceptable (0 - 0.35")     Caution (>0.35") Pressure Drop may be too high for certain applications

### Generated Noise (GN)

@ 5 sq.ft. face area

Length (in.)	Face Velocity (ft. per min)	Octave Band - Hz/Generated Noise (dB re 10 <sup>-12</sup> watts)							
		63	125	250	500	1K	2K	4K	8K
All	- 750	50	47	46	49	50	48	36	26
	- 500	51	42	45	45	43	37	23	24
	+ 500	50	39	34	32	31	28	20	23
	+ 750	51	45	39	36	39	40	30	25

GN correction chart at right must be used to correct GN to other face areas. →

Face Area (sq.ft.)	2.5	5	10	20	40	80
dB	-3	0	+3	+6	+9	+12

**Cross Section Sizes\***

**"A" dimension (in.)**  
 11  
 21-22  
 42-45  
 63-68  
 84-91  
 105-114  
 126-137  
 147-160  
 168-183  
 189-206  
 210-229  
 231-240

**"B" dimension**  
 ANY SIZE

**Approx. weight**  
 6.5 lbs/cu.ft.

See [Rectangular Silencer Cross-Section Dimensions](#) to ensure selection matches ductwork dimensions.

## RD-LV-F6

Rectangular Dissipative  
Low velocity silencer  
(<750 fpm)

How to Specify Example:

40 X 21 RD-LV-F6 X 60  
 ↑ Duct Width    ↑ Duct Height    ↑ Silencer Model    ↑ Silencer Length

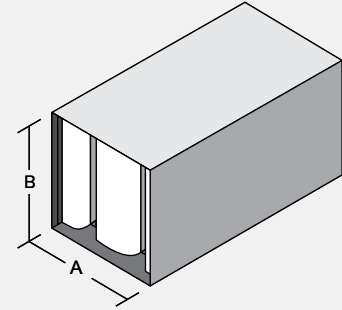

### Insertion Loss (IL)

+ : "forward flow" where noise & airflow move in same direction (e.g. supply side)

- : "reverse flow" where noise & airflow move in opposite directions (e.g. return side)

See [Silencer Selection Instructions](#). DIL above 50dB may be limited due to noise flanking around the silencer or along the duct walls. If more than 50dB DIL is required, contact your local Vibro-Acoustics representative or call **1-800-565-8401**.

Length (in.)	Face Velocity (ft. per min)	Octave Band - Hz/Dynamic Insertion Loss (dB)							
		63	125	250	500	1000	2000	4000	8000
36	- 750	6	8	15	23	30	24	15	11
	0	5	8	15	22	30	24	16	12
	+ 750	4	7	14	22	29	24	17	12
60	- 750	8	14	23	37	44	37	22	15
	0	8	13	22	36	44	40	25	17
	+ 750	7	12	21	35	44	41	26	17
84	- 750	13	20	32	46	55	47	32	18
	0	11	18	30	46	55	51	34	21
	+ 750	10	17	29	45	55	53	36	22
108	- 750	14	25	38	45	55	50	33	21
	0	14	22	36	46	55	55	37	23
	+ 750	12	21	35	46	55	55	39	25

### Pressure Drop (PD)

Pressure drops are reported in accordance with ASTM E477 methods and are based upon **ideal** flow conditions (5 diameters of straight duct on silencer inlet and 10 on outlet). Less than ideal conditions will result in an increase in pressure drop due to System Effects. See [Silencer System Effects Data](#).

Length (in.)	Face Velocity (ft. per min) / Pressure Drop (in.w.g.)						
	250	500	750	1000	1250	1500	1750
36	0.02	0.07	0.15	0.27	0.42	0.61	0.83
60	0.02	0.10	0.22	0.40	0.62	0.89	1.21
84	0.03	0.11	0.26	0.45	0.71	1.02	1.39
108	0.03	0.12	0.27	0.47	0.74	1.06	1.44

Acceptable (0 - 0.35")     Caution (>0.35") Pressure Drop may be too high for certain applications

### Generated Noise (GN)

@ 5 sq.ft. face area

Length (in.)	Face Velocity (ft. per min)	Octave Band - Hz/Generated Noise (dB re 10 <sup>-12</sup> watts)							
		63	125	250	500	1K	2K	4K	8K
All	- 750	50	46	45	48	51	49	36	26
	- 500	51	42	45	45	44	37	24	24
	+ 500	50	39	34	32	30	27	20	23
	+ 750	51	44	39	36	39	40	30	25

GN correction chart at right must be used to correct GN to other face areas. →

Face Area (sq.ft.)	2.5	5	10	20	40	80
dB	-3	0	+3	+6	+9	+12

#### Cross Section Sizes\*

"A" dimension (in.)  
 10  
 19-20  
 38-41  
 57-62  
 76-83  
 95-104  
 114-125  
 133-146  
 152-167  
 171-188  
 190-240

"B" dimension  
 ANY SIZE

Approx. weight  
 6.6 lbs/cu.ft.

See [Rectangular Silencer Cross-Section Dimensions](#) to ensure selection matches ductwork dimensions.

## RD-LV-F7

Rectangular Dissipative  
Low velocity silencer  
(<750 fpm)

How to Specify Example:

37 X 21 RD-LV-F7 X 60

↑ Duct Width    ↑ Duct Height    ↑ Silencer Model    ↑ Silencer Length

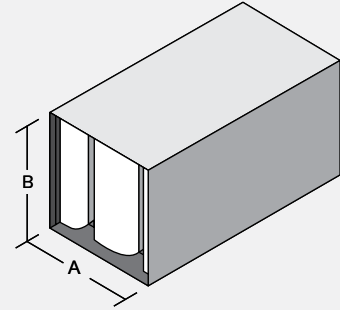

### Insertion Loss (IL)

+ : "forward flow" where noise & airflow move in same direction (e.g. supply side)

- : "reverse flow" where noise & airflow move in opposite directions (e.g. return side)

See [Silencer Selection Instructions](#). DIL above 50dB may be limited due to noise flanking around the silencer or along the duct walls. If more than 50dB DIL is required, contact your local Vibro-Acoustics representative or call **1-800-565-8401**.

Length (in.)	Face Velocity (ft. per min)	Octave Band - Hz/Dynamic Insertion Loss (dB)							
		63	125	250	500	1000	2000	4000	8000
36	- 750	6	8	19	28	31	25	17	12
	0	5	7	18	27	31	25	17	13
	+ 750	4	6	17	26	30	26	18	13
60	- 750	8	13	28	44	44	39	25	16
	0	7	11	26	44	44	43	27	19
	+ 750	7	11	25	42	44	43	29	20
84	- 750	12	19	40	55	52	48	36	21
	0	11	17	38	55	53	52	39	24
	+ 750	10	15	35	54	53	53	40	26
108	- 750	13	22	47	55	52	49	37	23
	0	13	20	44	55	53	54	42	27
	+ 750	12	19	42	55	52	55	43	29

### Pressure Drop (PD)

Pressure drops are reported in accordance with ASTM E477 methods and are based upon **ideal** flow conditions (5 diameters of straight duct on silencer inlet and 10 on outlet). Less than ideal conditions will result in an increase in pressure drop due to System Effects. See [Silencer System Effects Data](#).

Length (in.)	Face Velocity (ft. per min) / Pressure Drop (in.w.g.)						
	250	500	750	1000	1250	1500	1750
36	0.02	0.07	0.16	0.28	0.44	0.63	0.86
60	0.03	0.11	0.24	0.43	0.66	0.96	1.30
84	0.03	0.12	0.27	0.48	0.75	1.08	1.47
108	0.03	0.12	0.28	0.50	0.78	1.12	1.52

Acceptable (0 - 0.35")     Caution (>0.35") Pressure Drop may be too high for certain applications

### Generated Noise (GN)

@ 5 sq.ft. face area

Length (in.)	Face Velocity (ft. per min)	Octave Band - Hz/Generated Noise (dB re 10 <sup>-12</sup> watts)							
		63	125	250	500	1K	2K	4K	8K
All	- 750	50	46	44	48	51	49	37	26
	- 500	51	42	45	46	44	38	24	24
	+ 500	50	39	34	33	30	26	20	23
	+ 750	51	44	38	37	39	39	31	25

GN correction chart at right must be used to correct GN to other face areas. →

Face Area (sq.ft.)	2.5	5	10	20	40	80
dB	-3	0	+3	+6	+9	+12

**Cross Section Sizes\***

**"A" dimension (in.)**  
9  
17-18  
33-37  
50-56  
66-75  
83-94  
99-113  
116-240

**"B" dimension**  
ANY SIZE

**Approx. weight**  
6.7 lbs/cu.ft.

See [Rectangular Silencer Cross-Section Dimensions](#) to ensure selection matches ductwork dimensions.

## RD-LV-F8

Rectangular Dissipative  
Low velocity silencer  
(<750 fpm)

How to Specify Example:

14 X 22 RD-LV-F8 X 60  
 ↑ Duct Width    ↑ Duct Height    ↑ Silencer Model    ↑ Silencer Length

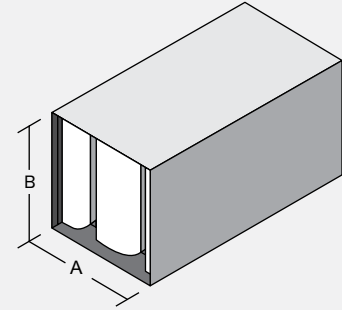

### Insertion Loss (IL)

+ : "forward flow" where noise & airflow move in same direction (e.g. supply side)

- : "reverse flow" where noise & airflow move in opposite directions (e.g. return side)

See [Silencer Selection Instructions](#). DIL above 50dB may be limited due to noise flanking around the silencer or along the duct walls. If more than 50dB DIL is required, contact your local Vibro-Acoustics representative or call **1-800-565-8401**.

Length (in.)	Face Velocity (ft. per min)	Octave Band - Hz/Dynamic Insertion Loss (dB)							
		63	125	250	500	1000	2000	4000	8000
36	- 750	4	9	17	28	30	27	20	17
	0	3	7	16	27	30	26	20	17
	+ 750	3	7	15	26	29	26	21	17
60	- 750	7	15	27	42	42	41	28	21
	0	6	13	25	40	42	43	29	22
	+ 750	5	12	24	39	41	43	29	22
84	- 750	10	21	37	55	53	55	36	25
	0	9	19	34	54	54	55	37	27
	+ 750	7	17	32	53	54	55	38	27
108	- 750	13	27	46	55	55	55	44	29
	0	11	25	43	55	55	55	46	33
	+ 750	9	22	41	55	55	55	47	32

### Pressure Drop (PD)

Pressure drops are reported in accordance with ASTM E477 methods and are based upon **ideal** flow conditions (5 diameters of straight duct on silencer inlet and 10 on outlet). Less than ideal conditions will result in an increase in pressure drop due to System Effects. See [Silencer System Effects Data](#).

Length (in.)	Face Velocity (ft. per min) / Pressure Drop (in.w.g.)						
	250	500	750	1000	1250	1500	1750
36	0.02	0.08	0.18	0.32	0.50	0.72	0.98
60	0.03	0.11	0.24	0.42	0.66	0.95	1.29
84	0.03	0.13	0.29	0.52	0.81	1.17	1.59
108	0.04	0.16	0.35	0.62	0.97	1.40	1.90

Acceptable (0 - 0.35")     Caution (>0.35") Pressure Drop may be too high for certain applications

### Generated Noise (GN)

@ 5 sq.ft. face area

Length (in.)	Face Velocity (ft. per min)	Octave Band - Hz/Generated Noise (dB re 10 <sup>-12</sup> watts)							
		63	125	250	500	1K	2K	4K	8K
All	- 750	51	41	39	45	50	48	36	27
	- 500	53	40	43	49	43	37	24	26
	+ 500	51	38	34	35	26	22	21	26
	+ 750	52	43	35	34	36	36	28	26

GN correction chart at right must be used to correct GN to other face areas. →

Face Area (sq.ft.)	2.5	5	10	20	40	80
dB	-3	0	+3	+6	+9	+12

**Cross Section Sizes\***

**"A" dimension (in.)**  
7-8  
14-16  
27-32  
41-49  
54-65  
68-240

**"B" dimension**  
ANY SIZE

**Approx. weight**  
7.0 lbs/cu.ft.

See [Rectangular Silencer Cross-Section Dimensions](#) to ensure selection matches ductwork dimensions.



## RD-LV-F9

Rectangular Dissipative  
Low velocity silencer  
(<750 fpm)

How to Specify Example:

21 X 21 RD-LV-F9 X 60  
 ↑ Duct Width    ↑ Duct Height    ↑ Silencer Model    ↑ Silencer Length

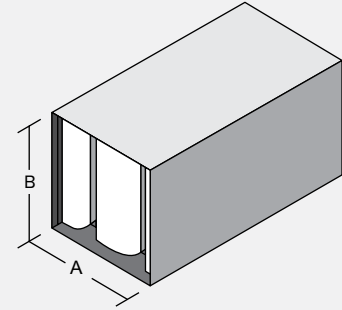

### Insertion Loss (IL)

+ : "forward flow" where noise & airflow move in same direction (e.g. supply side)

- : "reverse flow" where noise & airflow move in opposite directions (e.g. return side)

See [Silencer Selection Instructions](#). DIL above 50dB may be limited due to noise flanking around the silencer or along the duct walls. If more than 50dB DIL is required, contact your local Vibro-Acoustics representative or call **1-800-565-8401**.

Length (in.)	Face Velocity (ft. per min)	Octave Band - Hz/Dynamic Insertion Loss (dB)							
		63	125	250	500	1000	2000	4000	8000
36	- 750	5	7	16	28	39	32	21	13
	0	4	6	15	28	38	32	22	15
	+ 750	3	6	14	26	38	32	23	15
60	- 750	8	12	25	42	50	50	32	20
	0	6	11	23	41	51	55	36	24
	+ 750	6	10	22	40	51	55	38	25
84	- 750	11	21	37	53	52	55	50	27
	0	10	17	33	53	53	55	54	32
	+ 750	8	15	31	52	53	55	55	35
108	- 750	12	23	41	54	51	53	50	29
	0	12	19	38	55	53	55	55	36
	+ 750	10	18	36	54	53	55	55	38

### Pressure Drop (PD)

Pressure drops are reported in accordance with ASTM E477 methods and are based upon **ideal** flow conditions (5 diameters of straight duct on silencer inlet and 10 on outlet). Less than ideal conditions will result in an increase in pressure drop due to System Effects. See [Silencer System Effects Data](#).

Length (in.)	Face Velocity (ft. per min) / Pressure Drop (in.w.g.)						
	250	500	750	1000	1250	1500	1750
36	0.02	0.08	0.17	0.31	0.48	0.70	0.95
60	0.03	0.13	0.29	0.51	0.80	1.15	1.56
84	0.04	0.14	0.32	0.56	0.88	1.26	1.72
108	0.04	0.14	0.32	0.58	0.90	1.29	1.76

Acceptable (0 - 0.35")     Caution (>0.35") Pressure Drop may be too high for certain applications

### Generated Noise (GN)

@ 5 sq.ft. face area

Length (in.)	Face Velocity (ft. per min)	Octave Band - Hz/Generated Noise (dB re 10 <sup>-12</sup> watts)							
		63	125	250	500	1K	2K	4K	8K
All	- 750	51	44	41	46	52	51	39	27
	- 500	51	41	44	48	46	40	26	24
	+ 500	51	38	34	34	27	23	19	23
	+ 750	50	43	38	37	40	39	31	25

GN correction chart at right must be used to correct GN to other face areas. →

Face Area (sq.ft.)	2.5	5	10	20	40	80
dB	-3	0	+3	+6	+9	+12

**Cross Section Sizes\***

**"A" dimension (in.)**  
6  
10-13  
20-26  
30-240

**"B" dimension**  
ANY SIZE

**Approx. weight**  
7.3 lbs/cu.ft.

See [Rectangular Silencer Cross-Section Dimensions](#) to ensure selection matches ductwork dimensions.