

## RD-ULV-F1

Rectangular Dissipative  
Ultra low velocity silencer  
(<500 fpm)

How to Specify Example:

32 X 21 RD-ULV-F1 X 60

↑ Duct Width    ↑ Duct Height    ↑ Silencer Model    ↑ Silencer Length

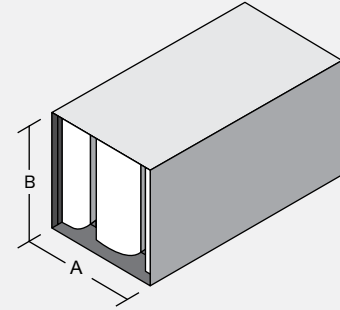

### Insertion Loss (IL)

+ : "forward flow" where noise & airflow move in same direction (e.g. supply side)

- : "reverse flow" where noise & airflow move in opposite directions (e.g. return side)

See [Silencer Selection Instructions](#). DIL above 50dB may be limited due to noise flanking around the silencer or along the duct walls. If more than 50dB DIL is required, contact your local Vibro-Acoustics representative or call **1-800-565-8401**.

Length (in.)	Face Velocity (ft. per min)	Octave Band - Hz/Dynamic Insertion Loss (dB)							
		63	125	250	500	1000	2000	4000	8000
36	- 500	7	16	20	19	26	20	17	14
	0	8	15	20	18	25	22	18	15
	+ 500	7	14	19	18	25	23	18	16
60	- 500	10	19	29	30	38	29	21	17
	0	10	18	29	29	38	30	24	19
	+ 500	9	18	28	28	38	30	24	20
84	- 500	13	22	39	41	51	38	26	19
	0	12	21	38	39	50	38	29	23
	+ 500	11	21	37	38	50	38	30	24
108	- 500	16	25	48	46	55	47	30	21
	0	14	24	47	46	55	45	35	27
	+ 500	13	24	46	46	55	46	36	28

### Pressure Drop (PD)

Pressure drops are reported in accordance with ASTM E477 methods and are based upon **ideal** flow conditions (5 diameters of straight duct on silencer inlet and 10 on outlet). Less than ideal conditions will result in an increase in pressure drop due to System Effects. See [Silencer System Effects Data](#).

Length (in.)	Face Velocity (ft. per min) / Pressure Drop (in.w.g.)						
	250	500	750	1000	1250	1500	1750
36	0.03	0.12	0.26	0.46	0.72	1.04	1.41
60	0.04	0.16	0.35	0.63	0.98	1.41	1.92
84	0.05	0.20	0.45	0.80	1.24	1.79	2.43
108	0.06	0.24	0.54	0.96	1.50	2.17	2.95

Acceptable (0 - 0.35")     Caution (>0.35") Pressure Drop may be too high for certain applications

### Generated Noise (GN)

@ 5 sq.ft. face area

Length (in.)	Face Velocity (ft. per min)	Octave Band - Hz/Generated Noise (dB re 10 <sup>-12</sup> watts)							
		63	125	250	500	1K	2K	4K	8K
All	- 750	55	42	38	41	47	49	40	32
	- 500	52	41	34	38	41	39	28	30
	+ 500	55	39	31	29	33	31	25	30
	+ 750	54	45	38	35	39	41	35	30

GN correction chart at right must be used to correct GN to other face areas. →

Face Area (sq.ft.)	2.5	5	10	20	40	80
dB	-3	0	+3	+6	+9	+12

**Cross Section Sizes\***

**"A" dimension (in.)**  
15-16  
29-32  
58-64  
87-96  
116-128  
145-160  
174-192  
203-224  
232-240

**"B" dimension**  
ANY SIZE

**Approx. weight**  
6.7 lbs/cu.ft.

See [Rectangular Silencer Cross-Section Dimensions](#) to ensure selection matches ductwork dimensions.

## RD-ULV-F2

Rectangular Dissipative  
Ultra low velocity silencer  
(<500 fpm)

How to Specify Example:

27 X 22 RD-ULV-F2 X 60

↑ Duct Width    ↑ Duct Height    ↑ Silencer Model    ↑ Silencer Length

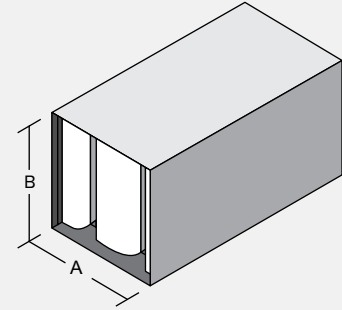

### Insertion Loss (IL)

+ : "forward flow" where noise & airflow move in same direction (e.g. supply side)

- : "reverse flow" where noise & airflow move in opposite directions (e.g. return side)

See [Silencer Selection Instructions](#). DIL above 50dB may be limited due to noise flanking around the silencer or along the duct walls. If more than 50dB DIL is required, contact your local Vibro-Acoustics representative or call **1-800-565-8401**.

Length (in.)	Face Velocity (ft. per min)	Octave Band - Hz/Dynamic Insertion Loss (dB)							
		63	125	250	500	1000	2000	4000	8000
36	- 500	7	14	20	20	27	21	16	13
	0	8	14	20	20	27	23	17	14
	+ 500	7	13	19	19	26	23	18	15
60	- 500	10	18	29	33	42	31	21	16
	0	10	17	28	32	41	32	23	18
	+ 500	9	16	27	31	41	33	24	19
84	- 500	13	22	38	43	53	41	26	18
	0	12	21	37	42	53	42	30	22
	+ 500	12	21	36	41	53	43	31	23
108	- 500	16	25	47	46	55	50	31	20
	0	14	23	45	46	55	51	35	25
	+ 500	13	24	44	46	55	51	37	27

### Pressure Drop (PD)

Pressure drops are reported in accordance with ASTM E477 methods and are based upon **ideal** flow conditions (5 diameters of straight duct on silencer inlet and 10 on outlet). Less than ideal conditions will result in an increase in pressure drop due to System Effects. See [Silencer System Effects Data](#).

Length (in.)	Face Velocity (ft. per min) / Pressure Drop (in.w.g.)						
	250	500	750	1000	1250	1500	1750
36	0.03	0.11	0.26	0.45	0.71	1.02	1.39
60	0.04	0.15	0.34	0.61	0.95	1.37	1.86
84	0.05	0.20	0.44	0.78	1.22	1.76	2.39
108	0.06	0.22	0.50	0.90	1.40	2.01	2.74

Acceptable (0 - 0.35")     Caution (>0.35") Pressure Drop may be too high for certain applications

### Generated Noise (GN)

@ 5 sq.ft. face area

Length (in.)	Face Velocity (ft. per min)	Octave Band - Hz/Generated Noise (dB re 10 <sup>-12</sup> watts)							
		63	125	250	500	1K	2K	4K	8K
All	- 750	54	43	40	42	47	50	40	31
	- 500	52	41	36	39	43	40	29	29
	+ 500	54	39	32	30	33	32	25	29
	+ 750	54	46	39	36	40	41	35	30

GN correction chart at right must be used to correct GN to other face areas. →

Face Area (sq.ft.)	2.5	5	10	20	40	80
dB	-3	0	+3	+6	+9	+12

**Cross Section Sizes\***

**"A" dimension (in.)**  
14  
27-28  
54-57  
81-86  
108-115  
135-144  
162-173  
189-202  
216-231

**"B" dimension**  
ANY SIZE

**Approx. weight**  
6.7 lbs/cu.ft.

See [Rectangular Silencer Cross-Section Dimensions](#) to ensure selection matches ductwork dimensions.

## RD-ULV-F3

Rectangular Dissipative  
Ultra low velocity silencer  
(<500 fpm)

How to Specify Example:

25 X 21 RD-ULV-F3 X 60  
 ↑ Duct Width    ↑ Duct Height    ↑ Silencer Model    ↑ Silencer Length

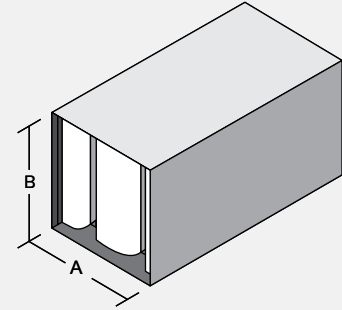

### Insertion Loss (IL)

+ : "forward flow" where noise & airflow move in same direction (e.g. supply side)

- : "reverse flow" where noise & airflow move in opposite directions (e.g. return side)

See [Silencer Selection Instructions](#). DIL above 50dB may be limited due to noise flanking around the silencer or along the duct walls. If more than 50dB DIL is required, contact your local Vibro-Acoustics representative or call **1-800-565-8401**.

Length (in.)	Face Velocity (ft. per min)	Octave Band - Hz/Dynamic Insertion Loss (dB)							
		63	125	250	500	1000	2000	4000	8000
36	- 500	8	13	20	22	28	22	15	12
	0	8	13	19	22	28	23	16	13
	+ 500	7	13	18	21	27	24	17	14
60	- 500	10	17	28	37	45	33	21	15
	0	10	16	28	36	44	35	23	17
	+ 500	9	15	27	35	44	36	24	18
84	- 500	14	22	37	46	55	44	26	16
	0	13	21	36	44	55	47	30	21
	+ 500	12	20	35	44	55	48	31	22
108	- 500	15	25	45	46	55	54	32	19
	0	14	23	44	46	55	55	36	24
	+ 500	13	23	43	46	55	55	37	26

### Pressure Drop (PD)

Pressure drops are reported in accordance with ASTM E477 methods and are based upon **ideal** flow conditions (5 diameters of straight duct on silencer inlet and 10 on outlet). Less than ideal conditions will result in an increase in pressure drop due to System Effects. See [Silencer System Effects Data](#).

Length (in.)	Face Velocity (ft. per min) / Pressure Drop (in.w.g.)						
	250	500	750	1000	1250	1500	1750
36	0.03	0.11	0.25	0.45	0.70	1.01	1.37
60	0.04	0.15	0.33	0.59	0.92	1.33	1.80
84	0.05	0.19	0.43	0.77	1.20	1.72	2.34
108	0.05	0.21	0.47	0.83	1.29	1.86	2.53

Acceptable (0 - 0.35")     Caution (>0.35") Pressure Drop may be too high for certain applications

### Generated Noise (GN)

@ 5 sq.ft. face area

Length (in.)	Face Velocity (ft. per min)	Octave Band - Hz/Generated Noise (dB re 10 <sup>-12</sup> watts)							
		63	125	250	500	1K	2K	4K	8K
All	- 750	53	45	42	44	48	50	40	31
	- 500	51	42	38	41	44	41	29	29
	+ 500	52	40	33	30	33	32	24	28
	+ 750	53	47	40	36	40	42	36	29

GN correction chart at right must be used to correct GN to other face areas. →

Face Area (sq.ft.)	2.5	5	10	20	40	80
dB	-3	0	+3	+6	+9	+12

**Cross Section Sizes\***

**"A" dimension (in.)**  
 13  
 25-26  
 50-53  
 75-80  
 100-107  
 125-134  
 150-161  
 175-188  
 200-215  
 225-240

**"B" dimension ANY SIZE**

**Approx. weight 6.8 lbs/cu.ft.**

See [Rectangular Silencer Cross-Section Dimensions](#) to ensure selection matches ductwork dimensions.

## RD-ULV-F4

Rectangular Dissipative  
Ultra low velocity silencer  
(<500 fpm)

How to Specify Example:

47 X 22 RD-ULV-F4 X 60  
 ↑     ↑     ↑     ↑  
 Duct Width    Duct Height    Silencer Model    Silencer Length

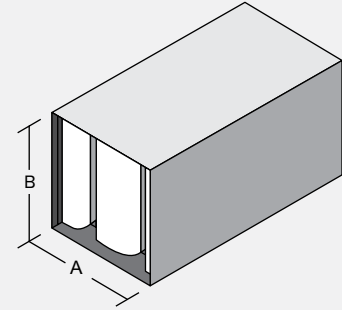

### Insertion Loss (IL)

+ : "forward flow" where noise & airflow move in same direction (e.g. supply side)

- : "reverse flow" where noise & airflow move in opposite directions (e.g. return side)

See [Silencer Selection Instructions](#). DIL above 50dB may be limited due to noise flanking around the silencer or along the duct walls. If more than 50dB DIL is required, contact your local Vibro-Acoustics representative or call **1-800-565-8401**.

Length (in.)	Face Velocity (ft. per min)	Octave Band - Hz/Dynamic Insertion Loss (dB)							
		63	125	250	500	1000	2000	4000	8000
36	- 500	8	12	20	24	29	23	14	11
	0	8	12	19	23	29	23	15	12
	+ 500	8	12	18	22	29	24	16	13
60	- 500	10	16	28	40	48	35	20	15
	0	9	14	27	39	47	38	23	15
	+ 500	9	14	26	38	47	38	24	17
84	- 500	14	21	36	46	55	47	26	15
	0	13	20	35	46	55	52	30	20
	+ 500	12	20	34	46	55	53	32	21
108	- 500	15	25	44	46	55	55	33	19
	0	14	22	43	46	55	55	36	22
	+ 500	13	22	41	46	55	55	38	24

### Pressure Drop (PD)

Pressure drops are reported in accordance with ASTM E477 methods and are based upon **ideal** flow conditions (5 diameters of straight duct on silencer inlet and 10 on outlet). Less than ideal conditions will result in an increase in pressure drop due to System Effects. See [Silencer System Effects Data](#).

Length (in.)	Face Velocity (ft. per min) / Pressure Drop (in.w.g.)						
	250	500	750	1000	1250	1500	1750
36	0.03	0.11	0.25	0.44	0.69	0.99	1.35
60	0.04	0.14	0.32	0.57	0.89	1.28	1.75
84	0.05	0.19	0.42	0.75	1.17	1.69	2.30
108	0.05	0.19	0.43	0.76	1.19	1.71	2.33

Acceptable (0 - 0.35")     Caution (>0.35") Pressure Drop may be too high for certain applications

### Generated Noise (GN)

@ 5 sq.ft. face area

Length (in.)	Face Velocity (ft. per min)	Octave Band - Hz/Generated Noise (dB re 10 <sup>-12</sup> watts)							
		63	125	250	500	1K	2K	4K	8K
All	- 750	52	46	44	46	49	51	41	30
	- 500	51	42	40	42	45	43	29	28
	+ 500	51	40	34	31	34	33	24	27
	+ 750	53	47	41	37	40	43	36	29

GN correction chart at right must be used to correct GN to other face areas. →

Face Area (sq.ft.)	2.5	5	10	20	40	80
dB	-3	0	+3	+6	+9	+12

#### Cross Section Sizes\*

"A" dimension (in.)  
 12  
 23-24  
 46-49  
 69-74  
 92-99  
 115-124  
 138-149  
 161-174  
 184-199  
 207-224  
 230-240

"B" dimension  
 ANY SIZE

Approx. weight  
 6.9 lbs/cu.ft.

See [Rectangular Silencer Cross-Section Dimensions](#) to ensure selection matches ductwork dimensions.

## RD-ULV-F5

Rectangular Dissipative  
Ultra low velocity silencer  
(<500 fpm)

How to Specify Example:

44 X 22 RD-ULV-F5 X 60

↑     ↑     ↑     ↑  
Duct Width   Duct Height   Silencer Model   Silencer Length

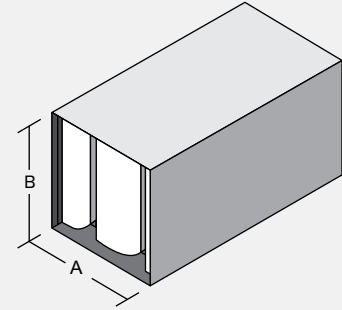

### Insertion Loss (IL)

+ : "forward flow" where noise & airflow move in same direction (e.g. supply side)

- : "reverse flow" where noise & airflow move in opposite directions (e.g. return side)

See [Silencer Selection Instructions](#). DIL above 50dB may be limited due to noise flanking around the silencer or along the duct walls. If more than 50dB DIL is required, contact your local Vibro-Acoustics representative or call **1-800-565-8401**.

Length (in.)	Face Velocity (ft. per min)	Octave Band - Hz/Dynamic Insertion Loss (dB)							
		63	125	250	500	1000	2000	4000	8000
36	- 500	7	12	19	24	32	25	16	12
	0	8	12	18	23	32	26	17	13
	+ 500	7	11	17	23	31	26	18	13
60	- 500	10	16	27	40	49	39	23	17
	0	9	14	26	39	48	42	26	17
	+ 500	8	14	25	37	48	42	27	19
84	- 500	13	22	35	46	55	50	30	18
	0	12	21	34	46	55	54	34	22
	+ 500	12	20	33	46	55	55	36	23
108	- 500	15	26	43	46	55	55	37	22
	0	14	23	42	46	55	55	40	25
	+ 500	13	23	40	46	55	55	42	27

### Pressure Drop (PD)

Pressure drops are reported in accordance with ASTM E477 methods and are based upon **ideal** flow conditions (5 diameters of straight duct on silencer inlet and 10 on outlet). Less than ideal conditions will result in an increase in pressure drop due to System Effects. See [Silencer System Effects Data](#).

Length (in.)	Face Velocity (ft. per min) / Pressure Drop (in.w.g.)						
	250	500	750	1000	1250	1500	1750
36	0.03	0.12	0.26	0.47	0.73	1.06	1.44
60	0.04	0.15	0.34	0.60	0.94	1.36	1.85
84	0.05	0.19	0.44	0.78	1.22	1.75	2.38
108	0.05	0.20	0.46	0.82	1.27	1.83	2.50

Acceptable (0 - 0.35")     Caution (>0.35") Pressure Drop may be too high for certain applications

### Generated Noise (GN)

@ 5 sq.ft. face area

Length (in.)	Face Velocity (ft. per min)	Octave Band - Hz/Generated Noise (dB re 10 <sup>-12</sup> watts)							
		63	125	250	500	1K	2K	4K	8K
All	- 750	52	46	44	46	49	51	41	31
	- 500	51	42	40	42	45	43	29	28
	+ 500	51	40	34	31	34	32	24	27
	+ 750	53	48	41	38	40	43	36	29

GN correction chart at right must be used to correct GN to other face areas. →

Face Area (sq.ft.)	2.5	5	10	20	40	80
dB	-3	0	+3	+6	+9	+12

**Cross Section Sizes\***

**"A" dimension (in.)**  
11  
21-22  
42-45  
63-68  
84-91  
105-114  
126-137  
147-160  
168-183  
189-206  
210-229  
231-240

**"B" dimension**  
ANY SIZE

**Approx. weight**  
6.7 lbs/cu.ft.

See [Rectangular Silencer Cross-Section Dimensions](#) to ensure selection matches ductwork dimensions.

## RD-ULV-F6

Rectangular Dissipative  
Ultra low velocity silencer  
(<500 fpm)

How to Specify Example:

40 X 21 RD-ULV-F6 X 60

↑ Duct Width    ↑ Duct Height    ↑ Silencer Model    ↑ Silencer Length

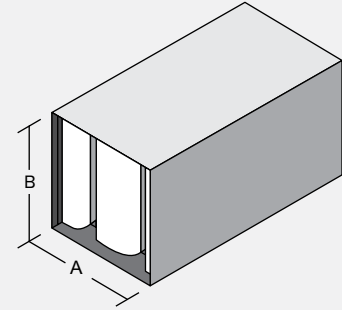

### Insertion Loss (IL)

+ : "forward flow" where noise & airflow move in same direction (e.g. supply side)

- : "reverse flow" where noise & airflow move in opposite directions (e.g. return side)

See [Silencer Selection Instructions](#). DIL above 50dB may be limited due to noise flanking around the silencer or along the duct walls. If more than 50dB DIL is required, contact your local Vibro-Acoustics representative or call **1-800-565-8401**.

Length (in.)	Face Velocity (ft. per min)	Octave Band - Hz/Dynamic Insertion Loss (dB)							
		63	125	250	500	1000	2000	4000	8000
36	- 500	7	12	18	24	35	28	17	12
	0	7	11	17	23	34	28	19	14
	+ 500	6	10	16	23	34	29	19	14
60	- 500	10	16	26	39	50	44	27	18
	0	9	14	25	38	49	45	30	20
	+ 500	8	14	24	37	49	46	31	21
84	- 500	13	22	34	46	55	52	34	21
	0	11	21	33	46	55	55	38	25
	+ 500	11	20	32	46	55	55	39	26
108	- 500	14	27	42	46	55	55	42	25
	0	13	24	41	46	55	55	44	28
	+ 500	12	24	39	46	55	55	46	30

### Pressure Drop (PD)

Pressure drops are reported in accordance with ASTM E477 methods and are based upon **ideal** flow conditions (5 diameters of straight duct on silencer inlet and 10 on outlet). Less than ideal conditions will result in an increase in pressure drop due to System Effects. See [Silencer System Effects Data](#).

Length (in.)	Face Velocity (ft. per min) / Pressure Drop (in.w.g.)						
	250	500	750	1000	1250	1500	1750
36	0.03	0.13	0.28	0.50	0.78	1.13	1.53
60	0.04	0.16	0.36	0.64	0.99	1.43	1.95
84	0.05	0.20	0.45	0.81	1.26	1.82	2.47
108	0.05	0.22	0.49	0.87	1.36	1.96	2.66

Acceptable (0 - 0.35")     Caution (>0.35") Pressure Drop may be too high for certain applications

### Generated Noise (GN)

@ 5 sq.ft. face area

Length (in.)	Face Velocity (ft. per min)	Octave Band - Hz/Generated Noise (dB re 10 <sup>-12</sup> watts)							
		63	125	250	500	1K	2K	4K	8K
All	- 750	52	46	44	46	50	52	42	31
	- 500	51	42	40	42	45	43	29	28
	+ 500	51	40	34	31	34	32	23	27
	+ 750	54	48	42	38	41	43	36	29

GN correction chart at right must be used to correct GN to other face areas. →

Face Area (sq.ft.)	2.5	5	10	20	40	80
dB	-3	0	+3	+6	+9	+12

**Cross Section Sizes\***

**"A" dimension (in.)**  
10  
19-20  
38-41  
57-62  
76-83  
95-104  
114-125  
133-146  
152-167  
171-188  
190-240

**"B" dimension**  
ANY SIZE

**Approx. weight**  
6.8 lbs/cu.ft.

See [Rectangular Silencer Cross-Section Dimensions](#) to ensure selection matches ductwork dimensions.

## RD-ULV-F7

Rectangular Dissipative  
Ultra low velocity silencer  
(<500 fpm)

**How to Specify Example:**

**37 X 21 RD-ULV-F7 X 60**

↑ Duct Width    ↑ Duct Height    ↑ Silencer Model    ↑ Silencer Length

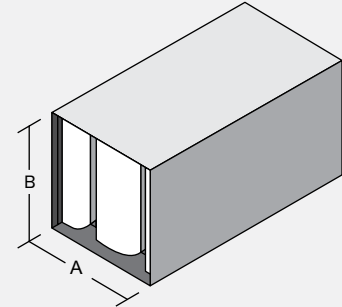

### Insertion Loss (IL)

+ : "forward flow" where noise & airflow move in same direction (e.g. supply side)

- : "reverse flow" where noise & airflow move in opposite directions (e.g. return side)

See [Silencer Selection Instructions](#). DIL above 50dB may be limited due to noise flanking around the silencer or along the duct walls. If more than 50dB DIL is required, contact your local Vibro-Acoustics representative or call **1-800-565-8401**.

Length (in.)	Face Velocity (ft. per min)	Octave Band - Hz/Dynamic Insertion Loss (dB)							
		63	125	250	500	1000	2000	4000	8000
36	- 500	7	10	22	29	35	29	19	13
	0	6	9	21	28	35	29	20	15
	+ 500	6	9	20	28	34	30	21	15
60	- 500	9	14	32	47	48	46	30	21
	0	9	13	31	46	48	47	33	22
	+ 500	8	13	30	44	47	47	34	23
84	- 500	12	21	42	55	54	53	38	24
	0	11	19	41	54	55	55	41	28
	+ 500	10	18	39	54	55	55	43	29
108	- 500	14	25	53	55	54	55	46	29
	0	13	23	50	55	55	55	48	32
	+ 500	12	22	48	55	54	55	49	34

### Pressure Drop (PD)

Pressure drops are reported in accordance with ASTM E477 methods and are based upon **ideal** flow conditions (5 diameters of straight duct on silencer inlet and 10 on outlet). Less than ideal conditions will result in an increase in pressure drop due to System Effects. See [Silencer System Effects Data](#).

Length (in.)	Face Velocity (ft. per min) / Pressure Drop (in.w.g.)						
	250	500	750	1000	1250	1500	1750
36	0.03	0.13	0.30	0.53	0.83	1.19	1.62
60	0.04	0.17	0.38	0.67	1.05	1.51	2.05
84	0.05	0.21	0.47	0.84	1.30	1.88	2.56
108	0.06	0.23	0.52	0.93	1.45	2.08	2.83

Acceptable (0 - 0.35")     Caution (>0.35") Pressure Drop may be too high for certain applications

### Generated Noise (GN)

@ 5 sq.ft. face area

Length (in.)	Face Velocity (ft. per min)	Octave Band - Hz/Generated Noise (dB re 10 <sup>-12</sup> watts)							
		63	125	250	500	1K	2K	4K	8K
All	- 750	52	46	45	46	50	53	43	32
	- 500	51	41	40	42	45	43	29	28
	+ 500	51	40	34	31	34	31	23	27
	+ 750	54	49	42	39	41	43	36	29

GN correction chart at right must be used to correct GN to other face areas. →

Face Area (sq.ft.)	2.5	5	10	20	40	80
dB	-3	0	+3	+6	+9	+12

**Cross Section Sizes\***

**"A" dimension (in.)**  
9  
17-18  
33-37  
50-56  
66-75  
83-94  
99-113  
116-240

**"B" dimension**  
ANY SIZE

**Approx. weight**  
6.9 lbs/cu.ft.

See [Rectangular Silencer Cross-Section Dimensions](#) to ensure selection matches ductwork dimensions.

## RD-ULV-F8

Rectangular Dissipative  
Ultra low velocity silencer  
(<500 fpm)

How to Specify Example:

14 X 22 RD-ULV-F8 X 60

↑ Duct Width    ↑ Duct Height    ↑ Silencer Model    ↑ Silencer Length

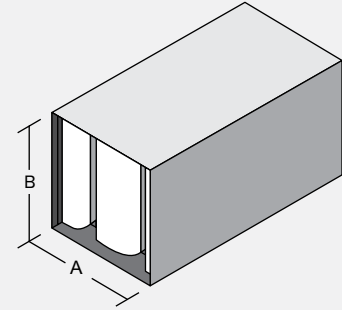

### Insertion Loss (IL)

+ : "forward flow" where noise & airflow move in same direction (e.g. supply side)

- : "reverse flow" where noise & airflow move in opposite directions (e.g. return side)

See [Silencer Selection Instructions](#). DIL above 50dB may be limited due to noise flanking around the silencer or along the duct walls. If more than 50dB DIL is required, contact your local Vibro-Acoustics representative or call **1-800-565-8401**.

Length (in.)	Face Velocity (ft. per min)	Octave Band - Hz/Dynamic Insertion Loss (dB)							
		63	125	250	500	1000	2000	4000	8000
36	- 500	5	11	19	28	35	30	24	20
	0	4	8	18	28	33	30	23	18
	+ 500	4	8	18	27	33	30	23	19
60	- 500	7	17	29	42	45	46	29	25
	0	6	14	28	40	44	46	30	24
	+ 500	6	14	27	40	44	46	30	25
84	- 500	10	23	38	55	55	55	35	30
	0	8	21	37	53	55	55	36	31
	+ 500	7	20	36	53	55	55	37	30
108	- 500	13	29	48	55	55	55	41	35
	0	10	28	46	55	55	55	43	37
	+ 500	9	26	45	55	55	55	44	36

### Pressure Drop (PD)

Pressure drops are reported in accordance with ASTM E477 methods and are based upon **ideal** flow conditions (5 diameters of straight duct on silencer inlet and 10 on outlet). Less than ideal conditions will result in an increase in pressure drop due to System Effects. See [Silencer System Effects Data](#).

Length (in.)	Face Velocity (ft. per min) / Pressure Drop (in.w.g.)						
	250	500	750	1000	1250	1500	1750
36	0.04	0.16	0.35	0.63	0.98	1.42	1.93
60	0.05	0.19	0.42	0.76	1.18	1.70	2.31
84	0.06	0.22	0.50	0.88	1.38	1.98	2.70
108	0.06	0.25	0.57	1.01	1.57	2.26	3.08

Acceptable (0 - 0.35")     Caution (>0.35") Pressure Drop may be too high for certain applications

### Generated Noise (GN)

@ 5 sq.ft. face area

Length (in.)	Face Velocity (ft. per min)	Octave Band - Hz/Generated Noise (dB re 10 <sup>-12</sup> watts)							
		63	125	250	500	1K	2K	4K	8K
All	- 750	53	43	43	46	49	52	42	33
	- 500	54	40	39	44	43	40	26	30
	+ 500	51	41	34	33	33	29	24	29
	+ 750	56	50	41	38	39	41	33	30

GN correction chart at right must be used to correct GN to other face areas. →

Face Area (sq.ft.)	2.5	5	10	20	40	80
dB	-3	0	+3	+6	+9	+12

**Cross Section Sizes\***

**"A" dimension (in.)**  
7-8  
14-16  
27-32  
41-49  
54-65  
68-240

**"B" dimension**  
ANY SIZE

**Approx. weight**  
7.2 lbs/cu.ft.

See [Rectangular Silencer Cross-Section Dimensions](#) to ensure selection matches ductwork dimensions.



## RD-ULV-F9

Rectangular Dissipative  
Ultra low velocity silencer  
(<500 fpm)

How to Specify Example:

21 X 21 RD-ULV-F9 X 60

↑ Duct Width    ↑ Duct Height    ↑ Silencer Model    ↑ Silencer Length

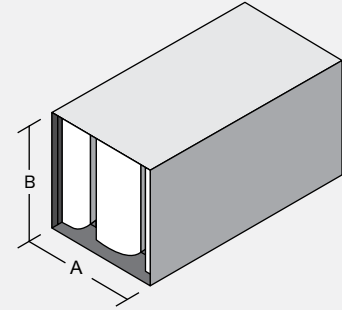

### Insertion Loss (IL)

+ : "forward flow" where noise & airflow move in same direction (e.g. supply side)

- : "reverse flow" where noise & airflow move in opposite directions (e.g. return side)

See [Silencer Selection Instructions](#). DIL above 50dB may be limited due to noise flanking around the silencer or along the duct walls. If more than 50dB DIL is required, contact your local Vibro-Acoustics representative or call **1-800-565-8401**.

Length (in.)	Face Velocity (ft. per min)	Octave Band - Hz/Dynamic Insertion Loss (dB)							
		63	125	250	500	1000	2000	4000	8000
36	- 500	5	10	18	29	43	35	24	15
	0	5	7	17	29	42	36	25	17
	+ 500	4	7	16	28	42	36	25	18
60	- 500	9	15	28	45	51	55	40	26
	0	8	13	27	44	51	55	42	29
	+ 500	7	13	26	43	50	55	44	29
84	- 500	10	22	38	53	53	55	50	33
	0	9	20	36	51	54	55	53	35
	+ 500	9	18	34	51	54	55	54	37
108	- 500	13	28	49	55	54	55	55	39
	0	12	25	46	55	53	55	55	42
	+ 500	10	24	43	55	53	55	55	43

### Pressure Drop (PD)

Pressure drops are reported in accordance with ASTM E477 methods and are based upon **ideal** flow conditions (5 diameters of straight duct on silencer inlet and 10 on outlet). Less than ideal conditions will result in an increase in pressure drop due to System Effects. See [Silencer System Effects Data](#).

Length (in.)	Face Velocity (ft. per min) / Pressure Drop (in.w.g.)						
	250	500	750	1000	1250	1500	1750
36	0.04	0.16	0.35	0.62	0.97	1.40	1.90
60	0.05	0.19	0.43	0.77	1.20	1.73	2.36
84	0.06	0.23	0.52	0.92	1.44	2.07	2.82
108	0.07	0.27	0.61	1.09	1.70	2.45	3.34

Acceptable (0 - 0.35")     Caution (>0.35") Pressure Drop may be too high for certain applications

### Generated Noise (GN)

@ 5 sq.ft. face area

Length (in.)	Face Velocity (ft. per min)	Octave Band - Hz/Generated Noise (dB re 10 <sup>-12</sup> watts)							
		63	125	250	500	1K	2K	4K	8K
All	- 750	53	47	45	47	51	55	45	34
	- 500	51	41	40	43	46	43	29	28
	+ 500	51	41	34	32	34	30	23	27
	+ 750	54	51	44	41	42	44	36	29

GN correction chart at right must be used to correct GN to other face areas. →

Face Area (sq.ft.)	2.5	5	10	20	40	80
dB	-3	0	+3	+6	+9	+12

#### Cross Section Sizes\*

"A" dimension (in.)  
6  
10-13  
20-26  
30-240

"B" dimension  
ANY SIZE

Approx. weight  
7.5 lbs/cu.ft.

See [Rectangular Silencer Cross-Section Dimensions](#) to ensure selection matches ductwork dimensions.