

RFMB-LV-F1

Rectangular Film MoldBlock
Low velocity silencer
(<750 fpm)

How to Specify Example:

32 X 21 RFMB-LV-F1 X 60

↑ Duct Width ↑ Duct Height ↑ Silencer Model ↑ Silencer Length

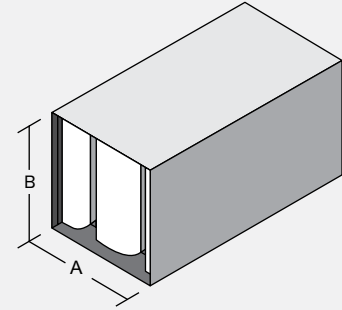

Insertion Loss (IL)

+ : "forward flow" where noise & airflow move in same direction (e.g. supply side)

- : "reverse flow" where noise & airflow move in opposite directions (e.g. return side)

See [Silencer Selection Instructions](#). DIL above 50dB may be limited due to noise flanking around the silencer or along the duct walls. If more than 50dB DIL is required, contact your local Vibro-Acoustics Representative or call **1-800-565-8401**.

Length (in.)	Face Velocity (ft. per min)	Octave Band - Hz/Dynamic Insertion Loss (dB)							
		63	125	250	500	1000	2000	4000	8000
36	- 750	9	10	13	13	18	19	17	11
	+ 750	7	9	12	12	17	23	18	11
60	- 750	11	13	21	23	28	27	20	12
	+ 750	9	12	19	22	27	29	21	12
84	- 750	14	15	29	33	38	36	23	13
	+ 750	11	14	27	31	38	35	25	13
108	- 750	17	18	37	39	46	45	26	14
	+ 750	14	17	34	39	46	43	29	15

Pressure Drop (PD)

Pressure drops are reported in accordance with ASTM E477 methods and are based upon **ideal** flow conditions (5 diameters of straight duct on silencer inlet and 10 on outlet). Less than ideal conditions will result in an increase in pressure drop due to System Effects. See [Silencer System Effects Data](#).

Length (in.)	Face Velocity (ft. per min) / Pressure Drop (in.w.g.)						
	250	500	750	1000	1250	1500	1750
36	0.02	0.07	0.15	0.27	0.42	0.61	0.83
60	0.02	0.09	0.20	0.36	0.56	0.80	1.09
84	0.03	0.11	0.25	0.44	0.70	1.00	1.36
108	0.03	0.13	0.30	0.53	0.83	1.20	1.63

Acceptable (0 - 0.35") Caution (>0.35") Pressure Drop may be too high for certain applications

Generated Noise (GN)

@ 5 sq.ft. face area

Length (in.)	Face Velocity (ft. per min)	Octave Band - Hz/Generated Noise (dB re 10 ⁻¹² watts)							
		63	125	250	500	1K	2K	4K	8K
All	- 750	58	43	42	44	47	48	37	32
	- 500	56	43	39	38	38	32	23	30
	+ 500	61	40	37	36	32	23	23	31
	+ 750	58	44	42	43	42	37	30	30

GN correction chart at right must be used to correct GN to other face areas. →

Face Area (sq.ft.)	2.5	5	10	20	40	80
dB	-3	0	+3	+6	+9	+12

Cross Section Sizes*

"A" dimension (in.)
14.5-15.5
29-31
58-62
87-93
116-124
145-155
174-186
203-217
232-248

"B" dimension ANY SIZE

See [Rectangular Silencer Cross-Section Dimensions](#) to ensure selection matches ductwork dimensions.

RFMB-LV-F2

Rectangular Film MoldBlock
Low velocity silencer
(<750 fpm)

How to Specify Example:

27 X 22 RFMB-LV-F2 X 60
 ↑ Duct Width ↑ Duct Height ↑ Silencer Model ↑ Silencer Length

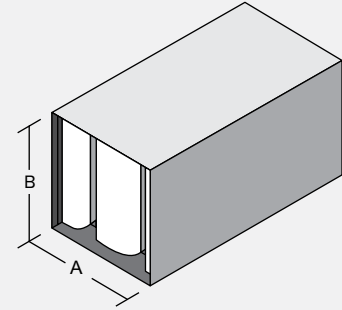

Insertion Loss (IL)

+ : "forward flow" where noise & airflow move in same direction (e.g. supply side)

- : "reverse flow" where noise & airflow move in opposite directions (e.g. return side)

See [Silencer Selection Instructions](#). DIL above 50dB may be limited due to noise flanking around the silencer or along the duct walls. If more than 50dB DIL is required, contact your local Vibro-Acoustics Representative or call **1-800-565-8401**.

Length (in.)	Face Velocity (ft. per min)	Octave Band - Hz/Dynamic Insertion Loss (dB)							
		63	125	250	500	1000	2000	4000	8000
36	- 750	9	9	12	14	19	21	16	10
	+ 750	7	8	11	13	18	24	17	10
60	- 750	11	12	19	24	29	31	20	11
	+ 750	9	11	18	23	28	32	21	11
84	- 750	14	15	27	34	40	41	23	12
	+ 750	11	13	25	32	39	40	26	12
108	- 750	17	18	35	39	46	47	26	13
	+ 750	14	17	33	39	46	48	30	14

Pressure Drop (PD)

Pressure drops are reported in accordance with ASTM E477 methods and are based upon **ideal** flow conditions (5 diameters of straight duct on silencer inlet and 10 on outlet). Less than ideal conditions will result in an increase in pressure drop due to System Effects. See [Silencer System Effects Data](#).

Length (in.)	Face Velocity (ft. per min) / Pressure Drop (in.w.g.)						
	250	500	750	1000	1250	1500	1750
36	0.02	0.07	0.15	0.26	0.41	0.59	0.81
60	0.02	0.09	0.20	0.35	0.55	0.79	1.08
84	0.03	0.11	0.24	0.43	0.67	0.97	1.32
108	0.03	0.12	0.28	0.50	0.77	1.11	1.52

Acceptable (0 - 0.35") Caution (>0.35") Pressure Drop may be too high for certain applications

Generated Noise (GN)

@ 5 sq.ft. face area

Length (in.)	Face Velocity (ft. per min)	Octave Band - Hz/Generated Noise (dB re 10 ⁻¹² watts)							
		63	125	250	500	1K	2K	4K	8K
All	- 750	57	44	44	45	48	49	37	31
	- 500	55	44	41	39	39	34	23	29
	+ 500	60	40	38	37	33	24	23	30
	+ 750	58	45	43	44	42	38	30	30

GN correction chart at right must be used to correct GN to other face areas. →

Face Area (sq.ft.)	2.5	5	10	20	40	80
dB	-3	0	+3	+6	+9	+12

Cross Section Sizes*

"A" dimension (in.)
 13.5-14.5
 27-29
 54-58
 81-8
 108-116
 135-145
 162-174
 189-203
 216-232

"B" dimension
 ANY SIZE

See [Rectangular Silencer Cross-Section Dimensions](#) to ensure selection matches ductwork dimensions.

RFMB-LV-F3

Rectangular Film MoldBlock
Low velocity silencer
(<750 fpm)

How to Specify Example:

25 X 21 RFMB-LV-F3 X 60
 ↑ Duct Width ↑ Duct Height ↑ Silencer Model ↑ Silencer Length

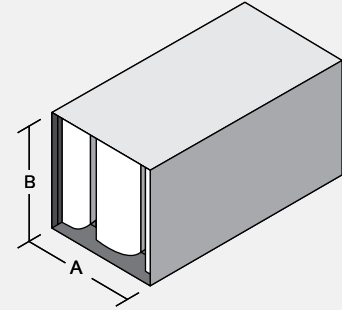

Insertion Loss (IL)

+ : "forward flow" where noise & airflow move in same direction (e.g. supply side)

- : "reverse flow" where noise & airflow move in opposite directions (e.g. return side)

See [Silencer Selection Instructions](#). DIL above 50dB may be limited due to noise flanking around the silencer or along the duct walls. If more than 50dB DIL is required, contact your local Vibro-Acoustics Representative or call **1-800-565-8401**.

Length (in.)	Face Velocity (ft. per min)	Octave Band - Hz/Dynamic Insertion Loss (dB)							
		63	125	250	500	1000	2000	4000	8000
36	- 750	8	8	11	16	20	23	15	9
	+ 750	7	7	10	14	18	24	16	9
60	- 750	11	11	18	25	31	35	19	10
	+ 750	9	10	17	24	29	35	21	10
84	- 750	14	14	25	35	43	46	24	11
	+ 750	12	13	23	33	40	45	26	12
108	- 750	16	19	34	38	45	49	27	12
	+ 750	14	16	31	39	45	52	31	14

Pressure Drop (PD)

Pressure drops are reported in accordance with ASTM E477 methods and are based upon **ideal** flow conditions (5 diameters of straight duct on silencer inlet and 10 on outlet). Less than ideal conditions will result in an increase in pressure drop due to System Effects. See [Silencer System Effects Data](#).

Length (in.)	Face Velocity (ft. per min) / Pressure Drop (in.w.g.)						
	250	500	750	1000	1250	1500	1750
36	0.02	0.06	0.14	0.26	0.40	0.58	0.79
60	0.02	0.09	0.19	0.35	0.54	0.78	1.06
84	0.03	0.10	0.23	0.41	0.65	0.93	1.27
108	0.03	0.11	0.26	0.46	0.71	1.03	1.40

Acceptable (0 - 0.35")

Caution (>0.35") Pressure Drop may be too high for certain applications

Generated Noise (GN)

@ 5 sq.ft. face area

Length (in.)	Face Velocity (ft. per min)	Octave Band - Hz/Generated Noise (dB re 10 ⁻¹² watts)							
		63	125	250	500	1K	2K	4K	8K
All	- 750	56	46	46	47	48	49	38	31
	- 500	55	44	43	40	40	35	24	28
	+ 500	58	40	39	38	33	24	22	29
	+ 750	58	46	44	44	42	39	31	30

GN correction chart at right must be used to correct GN to other face areas. →

Face Area (sq.ft.)	2.5	5	10	20	40	80
dB	-3	0	+3	+6	+9	+12

Cross Section Sizes*

"A" dimension (in.)
 12.5-13.5
 25-27
 50-54
 75-81
 100-108
 125-135
 150-162
 175-189
 200-216
 225-243

"B" dimension
 ANY SIZE

See [Rectangular Silencer Cross-Section Dimensions](#) to ensure selection matches ductwork dimensions.

RFMB-LV-F4

Rectangular Film MoldBlock
Low velocity silencer
(<750 fpm)

How to Specify Example:

47 X 22 RFMB-LV-F4 X 60
 ↑ Duct Width ↑ Duct Height ↑ Silencer Model ↑ Silencer Length

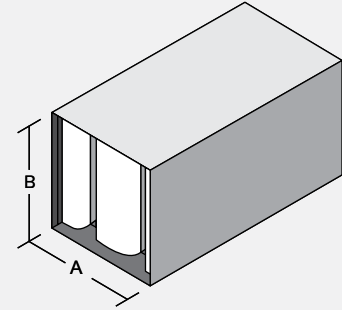

Insertion Loss (IL)

+ : "forward flow" where noise & airflow move in same direction (e.g. supply side)

- : "reverse flow" where noise & airflow move in opposite directions (e.g. return side)

See [Silencer Selection Instructions](#). DIL above 50dB may be limited due to noise flanking around the silencer or along the duct walls. If more than 50dB DIL is required, contact your local Vibro-Acoustics Representative or call **1-800-565-8401**.

Length (in.)	Face Velocity (ft. per min)	Octave Band - Hz/Dynamic Insertion Loss (dB)							
		63	125	250	500	1000	2000	4000	8000
36	- 750	8	7	11	17	21	25	14	8
	+ 750	7	6	10	15	19	25	15	8
60	- 750	11	10	17	26	33	38	19	9
	+ 750	9	9	15	24	31	38	21	9
84	- 750	14	14	23	36	45	51	24	11
	+ 750	12	12	21	33	42	50	27	11
108	- 750	15	19	33	38	45	51	27	12
	+ 750	14	16	30	39	44	55	33	13

Pressure Drop (PD)

Pressure drops are reported in accordance with ASTM E477 methods and are based upon **ideal** flow conditions (5 diameters of straight duct on silencer inlet and 10 on outlet). Less than ideal conditions will result in an increase in pressure drop due to System Effects. See [Silencer System Effects Data](#).

Length (in.)	Face Velocity (ft. per min) / Pressure Drop (in.w.g.)						
	250	500	750	1000	1250	1500	1750
36	0.02	0.06	0.14	0.25	0.39	0.56	0.77
60	0.02	0.09	0.19	0.34	0.53	0.77	1.04
84	0.03	0.10	0.23	0.40	0.63	0.90	1.23
108	0.03	0.10	0.24	0.42	0.66	0.94	1.29

Acceptable (0 - 0.35") Caution (>0.35") Pressure Drop may be too high for certain applications

Generated Noise (GN)

@ 5 sq.ft. face area

Length (in.)	Face Velocity (ft. per min)	Octave Band - Hz/Generated Noise (dB re 10 ⁻¹² watts)							
		63	125	250	500	1K	2K	4K	8K
All	- 750	55	47	48	48	49	50	38	30
	- 500	55	45	45	42	42	36	24	28
	+ 500	57	41	41	38	34	25	22	28
	+ 750	57	46	45	45	42	39	31	29

GN correction chart at right must be used to correct GN to other face areas. →

Face Area (sq.ft.)	2.5	5	10	20	40	80
dB	-3	0	+3	+6	+9	+12

Cross Section Sizes*

"A" dimension (in.)
 11.5-12.5
 23-25
 46-50
 69-75
 92-100
 115-125
 138-150
 161-175
 207-225

"B" dimension
 ANY SIZE

See [Rectangular Silencer Cross-Section Dimensions](#) to ensure selection matches ductwork dimensions.

RFMB-LV-F5

Rectangular Film MoldBlock
Low velocity silencer
(<750 fpm)

How to Specify Example:

44 X **22** **RFMB-LV-F5** X **60**

↑ Duct Width ↑ Duct Height ↑ Silencer Model ↑ Silencer Length

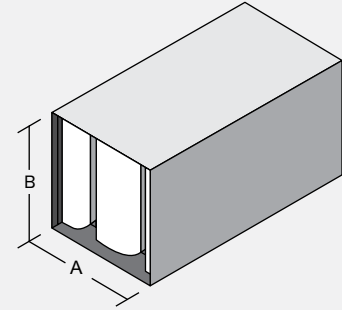

Insertion Loss (IL)

+ : "forward flow" where noise & airflow move in same direction (e.g. supply side)

- : "reverse flow" where noise & airflow move in opposite directions (e.g. return side)

See [Silencer Selection Instructions](#). DIL above 50dB may be limited due to noise flanking around the silencer or along the duct walls. If more than 50dB DIL is required, contact your local Vibro-Acoustics Representative or call **1-800-565-8401**.

Length (in.)	Face Velocity (ft. per min)	Octave Band - Hz/Dynamic Insertion Loss (dB)							
		63	125	250	500	1000	2000	4000	8000
36	- 750	8	7	11	17	22	26	16	8
	+ 750	7	6	10	16	21	26	17	8
60	- 750	11	11	17	27	34	39	22	10
	+ 750	9	9	15	25	32	39	24	10
84	- 750	14	15	22	36	47	51	28	12
	+ 750	12	12	21	34	44	52	31	12
108	- 750	15	19	32	39	46	51	30	12
	+ 750	14	16	29	40	46	55	36	14

Pressure Drop (PD)

Pressure drops are reported in accordance with ASTM E477 methods and are based upon **ideal** flow conditions (5 diameters of straight duct on silencer inlet and 10 on outlet). Less than ideal conditions will result in an increase in pressure drop due to System Effects. See [Silencer System Effects Data](#).

Length (in.)	Face Velocity (ft. per min) / Pressure Drop (in.w.g.)						
	250	500	750	1000	1250	1500	1750
36	0.02	0.06	0.15	0.26	0.41	0.59	0.80
60	0.02	0.09	0.21	0.37	0.58	0.83	1.13
84	0.03	0.11	0.24	0.43	0.67	0.96	1.31
108	0.03	0.11	0.25	0.45	0.70	1.00	1.37

Acceptable (0 - 0.35") Caution (>0.35") Pressure Drop may be too high for certain applications

Generated Noise (GN)

@ 5 sq.ft. face area

Length (in.)	Face Velocity (ft. per min)	Octave Band - Hz/Generated Noise (dB re 10 ⁻¹² watts)							
		63	125	250	500	1K	2K	4K	8K
All	- 750	55	47	47	49	50	50	38	30
	- 500	54	45	46	43	42	36	24	28
	+ 500	57	41	41	39	33	24	22	28
	+ 750	57	46	44	45	42	38	30	29

GN correction chart at right must be used to correct GN to other face areas. →

Face Area (sq.ft.)	2.5	5	10	20	40	80
dB	-3	0	+3	+6	+9	+12

Cross Section Sizes*

"A" dimension (in.)
10.5-11.5
21-23
42-46
63-69
84-92
105-115
126-138
147-161
168-184
189-207

"B" dimension
ANY SIZE

See [Rectangular Silencer Cross-Section Dimensions](#) to ensure selection matches ductwork dimensions.

RFMB-LV-F6

Rectangular Film MoldBlock
Low velocity silencer
(<750 fpm)

How to Specify Example:

40 X 21 RFMB-LV-F6 X 60
 ↑ Duct Width ↑ Duct Height ↑ Silencer Model ↑ Silencer Length

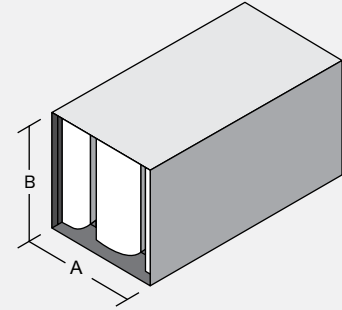

Insertion Loss (IL)

+ : "forward flow" where noise & airflow move in same direction (e.g. supply side)

- : "reverse flow" where noise & airflow move in opposite directions (e.g. return side)

See [Silencer Selection Instructions](#). DIL above 50dB may be limited due to noise flanking around the silencer or along the duct walls. If more than 50dB DIL is required, contact your local Vibro-Acoustics Representative or call **1-800-565-8401**.

Length (in.)	Face Velocity (ft. per min)	Octave Band - Hz/Dynamic Insertion Loss (dB)							
		63	125	250	500	1000	2000	4000	8000
36	- 750	8	7	11	18	24	27	18	8
	+ 750	6	6	10	16	22	27	19	8
60	- 750	11	11	17	27	36	39	25	10
	+ 750	9	9	15	25	34	40	27	11
84	- 750	15	15	22	37	48	51	32	12
	+ 750	12	13	20	34	46	53	35	13
108	- 750	15	19	32	40	47	52	34	13
	+ 750	14	16	29	40	47	55	40	15

Pressure Drop (PD)

Pressure drops are reported in accordance with ASTM E477 methods and are based upon **ideal** flow conditions (5 diameters of straight duct on silencer inlet and 10 on outlet). Less than ideal conditions will result in an increase in pressure drop due to System Effects. See [Silencer System Effects Data](#).

Length (in.)	Face Velocity (ft. per min) / Pressure Drop (in.w.g.)						
	250	500	750	1000	1250	1500	1750
36	0.02	0.07	0.15	0.27	0.42	0.61	0.83
60	0.02	0.10	0.22	0.40	0.62	0.89	1.21
84	0.03	0.11	0.26	0.45	0.71	1.02	1.39
108	0.03	0.12	0.27	0.47	0.74	1.06	1.44

Acceptable (0 - 0.35") Caution (>0.35") Pressure Drop may be too high for certain applications

Generated Noise (GN)

@ 5 sq.ft. face area

Length (in.)	Face Velocity (ft. per min)	Octave Band - Hz/Generated Noise (dB re 10 ⁻¹² watts)							
		63	125	250	500	1K	2K	4K	8K
All	- 750	54	47	47	49	50	50	38	30
	- 500	54	45	47	45	43	37	25	28
	+ 500	56	41	41	40	33	23	22	28
	+ 750	56	46	44	44	41	38	29	29

GN correction chart at right must be used to correct GN to other face areas. →

Face Area (sq.ft.)	2.5	5	10	20	40	80
dB	-3	0	+3	+6	+9	+12

Cross Section Sizes*

"A" dimension (in.)
 9.5-10.5
 19-21
 38-42
 57-63
 76-84
 95-105
 114-126
 133-147
 152-168
 171-189

"B" dimension ANY SIZE

See [Rectangular Silencer Cross-Section Dimensions](#) to ensure selection matches ductwork dimensions.

RFMB-LV-F7

Rectangular Film MoldBlock
Low velocity silencer
(<750 fpm)

How to Specify Example:

37 X 21 RFMB-F7 X 60

↑ Duct Width ↑ Duct Height ↑ Silencer Model ↑ Silencer Length

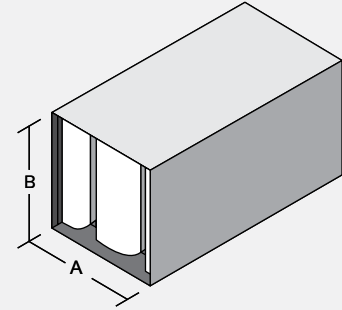

Insertion Loss (IL)

+ : "forward flow" where noise & airflow move in same direction (e.g. supply side)

- : "reverse flow" where noise & airflow move in opposite directions (e.g. return side)

See [Silencer Selection Instructions](#). DIL above 50dB may be limited due to noise flanking around the silencer or along the duct walls. If more than 50dB DIL is required, contact your local Vibro-Acoustics Representative or call **1-800-565-8401**.

Length (in.)	Face Velocity (ft. per min)	Octave Band - Hz/Dynamic Insertion Loss (dB)							
		63	125	250	500	1000	2000	4000	8000
36	- 750	7	6	11	18	25	29	20	9
	+ 750	6	6	10	17	24	28	21	8
60	- 750	11	11	17	28	37	40	28	11
	+ 750	9	9	15	26	36	41	30	11
84	- 750	15	16	22	37	49	51	36	13
	+ 750	12	13	20	35	48	55	39	14
108	- 750	15	19	31	40	49	53	37	13
	+ 750	14	16	28	41	49	55	43	16

Pressure Drop (PD)

Pressure drops are reported in accordance with ASTM E477 methods and are based upon **ideal** flow conditions (5 diameters of straight duct on silencer inlet and 10 on outlet). Less than ideal conditions will result in an increase in pressure drop due to System Effects. See [Silencer System Effects Data](#).

Length (in.)	Face Velocity (ft. per min) / Pressure Drop (in.w.g.)						
	250	500	750	1000	1250	1500	1750
36	0.02	0.07	0.16	0.28	0.44	0.63	0.86
60	0.03	0.11	0.24	0.43	0.66	0.96	1.30
84	0.03	0.12	0.27	0.48	0.75	1.08	1.47
108	0.03	0.12	0.28	0.50	0.78	1.12	1.52

Acceptable (0 - 0.35") Caution (>0.35") Pressure Drop may be too high for certain applications

Generated Noise (GN)

@ 5 sq.ft. face area

Length (in.)	Face Velocity (ft. per min)	Octave Band - Hz/Generated Noise (dB re 10 ⁻¹² watts)							
		63	125	250	500	1K	2K	4K	8K
All	- 750	54	47	47	50	51	50	39	30
	- 500	54	46	48	46	43	37	25	28
	+ 500	56	41	42	42	32	22	22	28
	+ 750	56	45	43	44	41	37	28	29

GN correction chart at right must be used to correct GN to other face areas. →

Face Area (sq.ft.)	2.5	5	10	20	40	80
dB	-3	0	+3	+6	+9	+12

Cross Section Sizes*

"A" dimension (in.)
8.25-9.5
16.5-19
33-38
49.5-57
66-76
82.5-95
99-114
115.5-133
132-152
148.5-171

"B" dimension
ANY SIZE

See [Rectangular Silencer Cross-Section Dimensions](#) to ensure selection matches ductwork dimensions.

RFMB-LV-F8

Rectangular Film MoldBlock
Low velocity silencer
(<750 fpm)

How to Specify Example:

14 X 22 RFMB-LV-F8 X 60
 ↑ Duct Width ↑ Duct Height ↑ Silencer Model ↑ Silencer Length

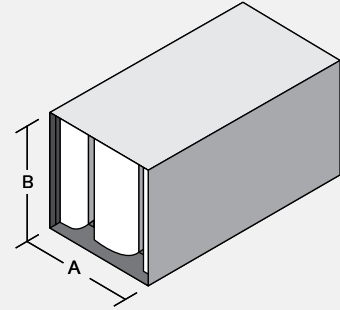

Insertion Loss (IL)

+ : "forward flow" where noise & airflow move in same direction (e.g. supply side)

- : "reverse flow" where noise & airflow move in opposite directions (e.g. return side)

See [Silencer Selection Instructions](#). DIL above 50dB may be limited due to noise flanking around the silencer or along the duct walls. If more than 50dB DIL is required, contact your local Vibro-Acoustics Representative or call **1-800-565-8401**.

Length (in.)	Face Velocity (ft. per min)	Octave Band - Hz/Dynamic Insertion Loss (dB)							
		63	125	250	500	1000	2000	4000	8000
36	- 750	5	7	12	19	23	26	24	11
	+ 750	4	6	11	18	22	26	25	10
60	- 750	9	12	19	31	39	41	29	12
	+ 750	7	10	17	30	39	43	31	12
84	- 750	13	17	26	43	55	55	34	13
	+ 750	10	14	23	41	55	55	36	14
108	- 750	17	22	33	44	55	55	42	15
	+ 750	12	18	29	44	55	55	45	16

Pressure Drop (PD)

Pressure drops are reported in accordance with ASTM E477 methods and are based upon **ideal** flow conditions (5 diameters of straight duct on silencer inlet and 10 on outlet). Less than ideal conditions will result in an increase in pressure drop due to System Effects. See [Silencer System Effects Data](#).

Length (in.)	Face Velocity (ft. per min) / Pressure Drop (in.w.g.)						
	250	500	750	1000	1250	1500	1750
36	0.02	0.08	0.18	0.32	0.50	0.72	0.98
60	0.03	0.10	0.24	0.42	0.66	0.95	1.29
84	0.03	0.13	0.29	0.52	0.81	1.17	1.59
108	0.04	0.16	0.35	0.62	0.97	1.40	1.90

Acceptable (0 - 0.35") Caution (>0.35") Pressure Drop may be too high for certain applications

Generated Noise (GN)

@ 5 sq.ft. face area

Length (in.)	Face Velocity (ft. per min)	Octave Band - Hz/Generated Noise (dB re 10 ⁻¹² watts)							
		63	125	250	500	1K	2K	4K	8K
All	- 750	54	43	44	49	50	48	36	30
	- 500	56	47	48	52	43	35	23	30
	+ 500	55	42	43	46	30	19	23	30
	+ 750	56	44	39	40	37	32	22	30

GN correction chart at right must be used to correct GN to other face areas. →

Face Area (sq.ft.)	2.5	5	10	20	40	80
dB	-3	0	+3	+6	+9	+12

Cross Section Sizes*

"A" dimension (in.)
 6.75-8.25
 13.5-16.5
 27-33
 40.5-49.5
 54-66
 67.5-82.5
 81-99
 94.5-115.5
 108-132
 121.5-148.5

"B" dimension
 ANY SIZE

See [Rectangular Silencer Cross-Section Dimensions](#) to ensure selection matches ductwork dimensions.

RFMB-LV-F9

Rectangular Film MoldBlock
Low velocity silencer
(<750 fpm)

How to Specify Example:

21 X **21** **RFMB-LV-F9** X **60**

↑ ↑ ↑ ↑

Duct Width Duct Height Silencer Model Silencer Length

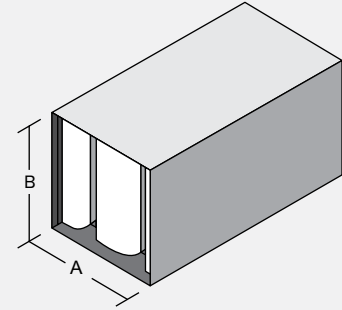

Insertion Loss (IL)

+ : "forward flow" where noise & airflow move in same direction (e.g. supply side)

- : "reverse flow" where noise & airflow move in opposite directions (e.g. return side)

See [Silencer Selection Instructions](#). DIL above 50dB may be limited due to noise flanking around the silencer or along the duct walls. If more than 50dB DIL is required, contact your local Vibro-Acoustics Representative or call **1-800-565-8401**.

Length (in.)	Face Velocity (ft. per min)	Octave Band - Hz/Dynamic Insertion Loss (dB)							
		63	125	250	500	1000	2000	4000	8000
36	- 750	6	6	11	20	30	32	27	9
	+ 750	5	5	10	18	28	31	27	9
60	- 750	11	12	16	29	42	41	38	13
	+ 750	9	9	14	27	41	45	39	13
84	- 750	16	17	22	38	53	51	49	16
	+ 750	13	14	19	36	53	55	51	17
108	- 750	15	19	29	42	53	54	48	15
	+ 750	13	15	25	42	54	55	54	19

Pressure Drop (PD)

Pressure drops are reported in accordance with ASTM E477 methods and are based upon **ideal** flow conditions (5 diameters of straight duct on silencer inlet and 10 on outlet). Less than ideal conditions will result in an increase in pressure drop due to System Effects. See [Silencer System Effects Data](#).

Length (in.)	Face Velocity (ft. per min) / Pressure Drop (in.w.g.)						
	250	500	750	1000	1250	1500	1750
36	0.02	0.08	0.17	0.31	0.48	0.70	0.95
60	0.03	0.13	0.29	0.51	0.80	1.15	1.56
84	0.04	0.14	0.32	0.56	0.88	1.26	1.72
108	0.04	0.14	0.32	0.57	0.90	1.29	1.76

Acceptable (0 - 0.35") Caution (>0.35") Pressure Drop may be too high for certain applications

Generated Noise (GN)

@ 5 sq.ft. face area

Length (in.)	Face Velocity (ft. per min)	Octave Band - Hz/Generated Noise (dB re 10 ⁻¹² watts)							
		63	125	250	500	1K	2K	4K	8K
All	- 750	54	46	47	51	52	51	39	31
	- 500	54	47	50	51	45	38	26	28
	+ 500	54	42	43	45	31	20	21	28
	+ 750	54	44	42	43	40	43	25	29

GN correction chart at right must be used to correct GN to other face areas. →

Face Area (sq.ft.)	2.5	5	10	20	40	80
dB	-3	0	+3	+6	+9	+12

Cross Section Sizes*

"A" dimension (in.)
5-6.75
10-13.5
20-27
30-40.5
40-54
50-67.5
60-81
70-94.5
80-108
90-121.5

"B" dimension
ANY SIZE

See [Rectangular Silencer Cross-Section Dimensions](#) to ensure selection matches ductwork dimensions.