

RFMB-MV-F1

Rectangular Film MoldBlock
Medium velocity silencer
(<1250 fpm)

How to Specify Example:

32 X 21 RFMB-MV-F1 X 60
 ↑ Duct Width ↑ Duct Height ↑ Silencer Model ↑ Silencer Length

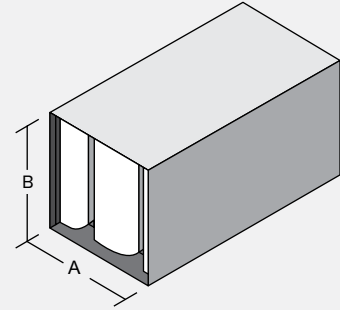

Insertion Loss (IL)

+ : "forward flow" where noise & airflow move in same direction (e.g. supply side)

- : "reverse flow" where noise & airflow move in opposite directions (e.g. return side)

See [Silencer Selection Instructions](#). DIL above 50dB may be limited due to noise flanking around the silencer or along the duct walls. If more than 50dB DIL is required, contact your local Vibro-Acoustics Representative or call **1-800-565-8401**.

Length (in.)	Face Velocity (ft. per min)	Octave Band - Hz/Dynamic Insertion Loss (dB)							
		63	125	250	500	1000	2000	4000	8000
36	- 1250	4	7	14	17	16	15	15	9
	+ 1250	3	5	12	16	15	16	14	8
60	- 1250	7	10	20	21	24	25	17	10
	+ 1250	5	8	18	19	23	24	17	9
84	- 1250	10	14	27	25	32	34	19	10
	+ 1250	8	11	25	23	31	33	20	10
108	- 1250	12	17	35	32	40	42	21	12
	+ 1250	10	14	31	29	40	40	23	12

Pressure Drop (PD)

Pressure drops are reported in accordance with ASTM E477 methods and are based upon **ideal** flow conditions (5 diameters of straight duct on silencer inlet and 10 on outlet). Less than ideal conditions will result in an increase in pressure drop due to System Effects. See [Silencer System Effects Data](#).

Length (in.)	Face Velocity (ft. per min) / Pressure Drop (in.w.g.)						
	500	750	1000	1250	1500	1750	2000
36	0.03	0.07	0.13	0.21	0.30	0.40	0.53
60	0.04	0.10	0.18	0.27	0.40	0.54	0.70
84	0.05	0.12	0.22	0.34	0.49	0.67	0.88
108	0.07	0.15	0.26	0.41	0.59	0.81	1.06

Acceptable (0 - 0.35") Caution (>0.35") Pressure Drop may be too high for certain applications

Generated Noise (GN)

@ 5 sq.ft. face area

Length (in.)	Face Velocity (ft. per min)	Octave Band - Hz/Generated Noise (dB re 10 ⁻¹² watts)							
		63	125	250	500	1K	2K	4K	8K
All	- 1250	52	50	50	51	52	56	46	32
	- 750	53	42	42	42	44	39	25	24
	+ 750	52	38	36	33	32	29	21	24
	+ 1250	56	51	47	45	45	47	39	30

GN correction chart at right must be used to correct GN to other face areas. →

Face Area (sq.ft.)	2.5	5	10	20	40	80
dB	-3	0	+3	+6	+9	+12

Cross Section Sizes*

"A" dimension (in.)
14.5-15.5
29-31
58-62
87-63
116-124
145-155
174-186
203-217
232-248

"B" dimension
ANY SIZE

See [Rectangular Silencer Cross-Section Dimensions](#) to ensure selection matches ductwork dimensions.

RFMB-MV-F2

Rectangular Film MoldBlock
Medium velocity silencer
(<1250 fpm)

How to Specify Example:

27 X 22 RFMB-MV-F2 X 60

↑ Duct Width ↑ Duct Height ↑ Silencer Model ↑ Silencer Length

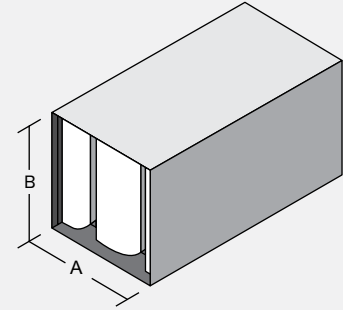

Insertion Loss (IL)

+ : "forward flow" where noise & airflow move in same direction (e.g. supply side)

- : "reverse flow" where noise & airflow move in opposite directions (e.g. return side)

See [Silencer Selection Instructions](#). DIL above 50dB may be limited due to noise flanking around the silencer or along the duct walls. If more than 50dB DIL is required, contact your local Vibro-Acoustics Representative or call **1-800-565-8401**.

Length (in.)	Face Velocity (ft. per min)	Octave Band - Hz/Dynamic Insertion Loss (dB)							
		63	125	250	500	1000	2000	4000	8000
36	- 1250	4	6	13	18	17	15	13	8
	+ 1250	3	5	12	16	16	16	13	8
60	- 1250	7	9	19	22	25	25	16	9
	+ 1250	6	8	17	20	24	26	16	9
84	- 1250	11	13	24	26	33	36	18	10
	+ 1250	8	10	22	24	32	36	19	9
108	- 1250	12	16	33	32	42	42	20	10
	+ 1250	9	14	30	31	42	42	23	11

Pressure Drop (PD)

Pressure drops are reported in accordance with ASTM E477 methods and are based upon **ideal** flow conditions (5 diameters of straight duct on silencer inlet and 10 on outlet). Less than ideal conditions will result in an increase in pressure drop due to System Effects. See [Silencer System Effects Data](#).

Length (in.)	Face Velocity (ft. per min) / Pressure Drop (in.w.g.)						
	500	750	1000	1250	1500	1750	2000
36	0.03	0.07	0.12	0.19	0.27	0.37	0.49
60	0.04	0.09	0.16	0.26	0.37	0.50	0.66
84	0.05	0.11	0.20	0.31	0.45	0.61	0.80
108	0.06	0.13	0.24	0.37	0.54	0.73	0.96

Acceptable (0 - 0.35") Caution (>0.35") Pressure Drop may be too high for certain applications

Generated Noise (GN)

@ 5 sq.ft. face area

Length (in.)	Face Velocity (ft. per min)	Octave Band - Hz/Generated Noise (dB re 10 ⁻¹² watts)							
		63	125	250	500	1K	2K	4K	8K
All	- 1250	53	50	49	50	52	55	46	32
	- 750	53	42	41	41	44	38	24	24
	+ 750	52	38	36	34	32	29	21	24
	+ 1250	56	51	48	45	45	47	39	30

GN correction chart at right must be used to correct GN to other face areas. →

Face Area (sq.ft.)	2.5	5	10	20	40	80
dB	-3	0	+3	+6	+9	+12

Cross Section Sizes*

"A" dimension (in.)

13.5-14.5
27-29
54-58
81-87
108-116
135-145
162-174
189-203
216-232

"B" dimension ANY SIZE

See [Rectangular Silencer Cross-Section Dimensions](#) to ensure selection matches ductwork dimensions.

RFMB-MV-F3

Rectangular Film MoldBlock
Medium velocity silencer
(<1250 fpm)

How to Specify Example:

25 X 21 RFMB-MV-F3 X 60
 ↑ Duct Width ↑ Duct Height ↑ Silencer Model ↑ Silencer Length

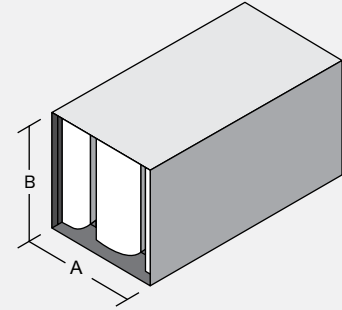

Insertion Loss (IL)

+ : "forward flow" where noise & airflow move in same direction (e.g. supply side)

- : "reverse flow" where noise & airflow move in opposite directions (e.g. return side)

See [Silencer Selection Instructions](#). DIL above 50dB may be limited due to noise flanking around the silencer or along the duct walls. If more than 50dB DIL is required, contact your local Vibro-Acoustics Representative or call **1-800-565-8401**.

Length (in.)	Face Velocity (ft. per min)	Octave Band - Hz/Dynamic Insertion Loss (dB)							
		63	125	250	500	1000	2000	4000	8000
36	- 1250	4	6	13	19	17	16	12	7
	+ 1250	3	5	11	17	16	16	12	7
60	- 1250	8	9	17	23	26	26	15	8
	+ 1250	6	7	15	21	25	27	15	8
84	- 1250	12	12	21	27	35	37	18	9
	+ 1250	9	10	18	24	33	38	18	9
108	- 1250	12	16	32	32	43	42	20	9
	+ 1250	9	14	29	33	44	45	22	11

Pressure Drop (PD)

Pressure drops are reported in accordance with ASTM E477 methods and are based upon **ideal** flow conditions (5 diameters of straight duct on silencer inlet and 10 on outlet). Less than ideal conditions will result in an increase in pressure drop due to System Effects. See [Silencer System Effects Data](#).

Length (in.)	Face Velocity (ft. per min) / Pressure Drop (in.w.g.)						
	500	750	1000	1250	1500	1750	2000
36	0.03	0.06	0.11	0.17	0.25	0.34	0.44
60	0.04	0.09	0.15	0.24	0.34	0.47	0.61
84	0.05	0.10	0.18	0.28	0.41	0.55	0.72
108	0.05	0.12	0.21	0.34	0.48	0.66	0.86

Acceptable (0 - 0.35") Caution (>0.35") Pressure Drop may be too high for certain applications

Generated Noise (GN)

@ 5 sq.ft. face area

Length (in.)	Face Velocity (ft. per min)	Octave Band - Hz/Generated Noise (dB re 10 ⁻¹² watts)							
		63	125	250	500	1K	2K	4K	8K
All	- 1250	53	51	49	50	51	54	45	33
	- 750	53	42	41	41	43	36	24	24
	+ 750	52	38	37	35	33	29	21	24
	+ 1250	56	52	48	46	45	47	39	31

GN correction chart at right must be used to correct GN to other face areas. →

Face Area (sq.ft.)	2.5	5	10	20	40	80
dB	-3	0	+3	+6	+9	+12

Cross Section Sizes*

"A" dimension (in.)
12.5-13.5
25-27
50-54
75-81
100-108
125-135
150-162
175-189
200-216
225-243

"B" dimension
ANY SIZE

See [Rectangular Silencer Cross-Section Dimensions](#) to ensure selection matches ductwork dimensions.

RFMB-MV-F4

Rectangular Film MoldBlock
Medium velocity silencer
(<1250 fpm)

How to Specify Example:

47 X 22 RFMB-MV-F4 X 60

↑ Duct Width ↑ Duct Height ↑ Silencer Model ↑ Silencer Length

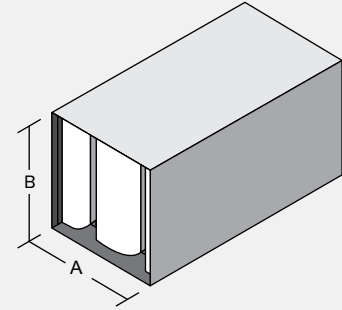

Insertion Loss (IL)

+ : "forward flow" where noise & airflow move in same direction (e.g. supply side)

- : "reverse flow" where noise & airflow move in opposite directions (e.g. return side)

See [Silencer Selection Instructions](#). DIL above 50dB may be limited due to noise flanking around the silencer or along the duct walls. If more than 50dB DIL is required, contact your local Vibro-Acoustics Representative or call **1-800-565-8401**.

Length (in.)	Face Velocity (ft. per min)	Octave Band - Hz/Dynamic Insertion Loss (dB)							
		63	125	250	500	1000	2000	4000	8000
36	- 1250	4	6	12	19	17	16	11	6
	+ 1250	3	5	11	18	17	16	12	6
60	- 1250	8	8	15	24	27	27	14	7
	+ 1250	7	7	13	22	25	28	15	7
84	- 1250	13	11	17	28	37	39	17	8
	+ 1250	10	9	15	25	34	41	18	8
108	- 1250	12	16	30	32	45	43	19	8
	+ 1250	8	14	28	35	46	48	22	10

Pressure Drop (PD)

Pressure drops are reported in accordance with ASTM E477 methods and are based upon **ideal** flow conditions (5 diameters of straight duct on silencer inlet and 10 on outlet). Less than ideal conditions will result in an increase in pressure drop due to System Effects. See [Silencer System Effects Data](#).

Length (in.)	Face Velocity (ft. per min) / Pressure Drop (in.w.g.)						
	500	750	1000	1250	1500	1750	2000
36	0.03	0.06	0.10	0.16	0.23	0.31	0.40
60	0.04	0.08	0.14	0.22	0.32	0.43	0.56
84	0.04	0.09	0.16	0.25	0.36	0.49	0.64
108	0.05	0.11	0.19	0.30	0.43	0.58	0.76

Acceptable (0 - 0.35") Caution (>0.35") Pressure Drop may be too high for certain applications

Generated Noise (GN)

@ 5 sq.ft. face area

Length (in.)	Face Velocity (ft. per min)	Octave Band - Hz/Generated Noise (dB re 10 ⁻¹² watts)							
		63	125	250	500	1K	2K	4K	8K
All	- 1250	54	51	49	50	51	53	44	33
	- 750	52	41	40	41	42	35	23	24
	+ 750	51	38	37	36	33	28	21	24
	+ 1250	56	52	48	46	46	46	39	31

GN correction chart at right must be used to correct GN to other face areas. →

Face Area (sq.ft.)	2.5	5	10	20	40	80
dB	-3	0	+3	+6	+9	+12

Cross Section Sizes*

"A" dimension (in.)

11.5–12.5
23–25
46–50
69–75
92–100
115–125
138–150
161–175
207–225

"B" dimension ANY SIZE

See [Rectangular Silencer Cross-Section Dimensions](#) to ensure selection matches ductwork dimensions.

RFMB-MV-F5

Rectangular Film MoldBlock
Medium velocity silencer
(<1250 fpm)

How to Specify Example:

44 X **22** **RFMB-MV-F5** X **60**

↑ Duct Width ↑ Duct Height ↑ Silencer Model ↑ Silencer Length

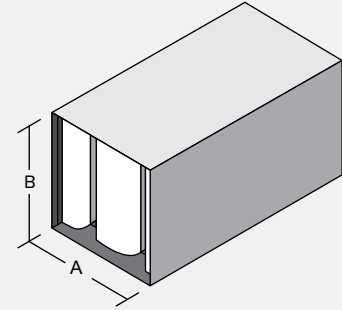

Insertion Loss (IL)

+ : "forward flow" where noise & airflow move in same direction (e.g. supply side)

- : "reverse flow" where noise & airflow move in opposite directions (e.g. return side)

See [Silencer Selection Instructions](#). DIL above 50dB may be limited due to noise flanking around the silencer or along the duct walls. If more than 50dB DIL is required, contact your local Vibro-Acoustics Representative or call **1-800-565-8401**.

Length (in.)	Face Velocity (ft. per min)	Octave Band - Hz/Dynamic Insertion Loss (dB)							
		63	125	250	500	1000	2000	4000	8000
36	- 1250	4	6	12	19	19	17	13	6
	+ 1250	3	4	10	18	18	17	13	6
60	- 1250	8	8	15	24	29	29	17	8
	+ 1250	6	7	13	22	27	30	17	8
84	- 1250	12	11	18	30	39	40	21	9
	+ 1250	9	9	15	27	36	43	22	9
108	- 1250	11	16	29	33	45	43	22	8
	+ 1250	8	13	26	35	46	48	26	11

Pressure Drop (PD)

Pressure drops are reported in accordance with ASTM E477 methods and are based upon **ideal** flow conditions (5 diameters of straight duct on silencer inlet and 10 on outlet). Less than ideal conditions will result in an increase in pressure drop due to System Effects. See [Silencer System Effects Data](#).

Length (in.)	Face Velocity (ft. per min) / Pressure Drop (in.w.g.)						
	500	750	1000	1250	1500	1750	2000
36	0.03	0.06	0.10	0.16	0.23	0.31	0.41
60	0.04	0.08	0.15	0.23	0.33	0.45	0.59
84	0.05	0.10	0.19	0.29	0.42	0.57	0.74
108	0.05	0.11	0.20	0.31	0.45	0.61	0.80

Acceptable (0 - 0.35")

Caution (>0.35") Pressure Drop may be too high for certain applications

Generated Noise (GN)

@ 5 sq.ft. face area

Length (in.)	Face Velocity (ft. per min)	Octave Band - Hz/Generated Noise (dB re 10 ⁻¹² watts)							
		63	125	250	500	1K	2K	4K	8K
All	- 1250	55	51	49	50	50	51	43	33
	- 750	52	41	40	41	41	34	23	24
	+ 750	51	39	37	37	34	28	21	24
	+ 1250	56	52	48	46	46	46	39	32

GN correction chart at right must be used to correct GN to other face areas. →

Face Area (sq.ft.)	2.5	5	10	20	40	80
dB	-3	0	+3	+6	+9	+12

Cross Section Sizes*

"A" dimension (in.)
10.5–11.5
21–23
42–46
63–69
84–92
105–115
126–138
147–161
168–184
189–207

"B" dimension
ANY SIZE

See [Rectangular Silencer Cross-Section Dimensions](#) to ensure selection matches ductwork dimensions.

RFMB-MV-F6

Rectangular Film MoldBlock
Medium velocity silencer
(<1250 fpm)

How to Specify Example:

40 X 21 RFMB-MV-F6 X 60
 ↑ Duct Width ↑ Duct Height ↑ Silencer Model ↑ Silencer Length

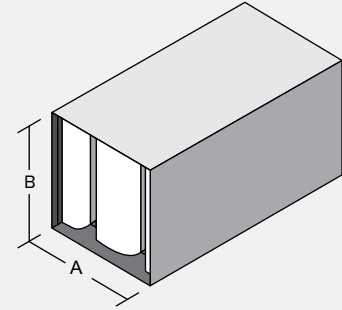

Insertion Loss (IL)

+ : "forward flow" where noise & airflow move in same direction (e.g. supply side)

- : "reverse flow" where noise & airflow move in opposite directions (e.g. return side)

See [Silencer Selection Instructions](#). DIL above 50dB may be limited due to noise flanking around the silencer or along the duct walls. If more than 50dB DIL is required, contact your local Vibro-Acoustics Representative or call **1-800-565-8401**.

Length (in.)	Face Velocity (ft. per min)	Octave Band - Hz/Dynamic Insertion Loss (dB)							
		63	125	250	500	1000	2000	4000	8000
36	- 1250	4	5	11	19	20	19	14	7
	+ 1250	3	4	10	17	20	19	14	7
60	- 1250	8	8	15	25	31	30	19	8
	+ 1250	6	7	13	23	29	31	20	8
84	- 1250	11	11	18	31	41	42	25	10
	+ 1250	9	9	16	28	38	44	27	10
108	- 1250	10	15	27	33	45	43	26	9
	+ 1250	7	12	24	35	47	49	31	12

Pressure Drop (PD)

Pressure drops are reported in accordance with ASTM E477 methods and are based upon **ideal** flow conditions (5 diameters of straight duct on silencer inlet and 10 on outlet). Less than ideal conditions will result in an increase in pressure drop due to System Effects. See [Silencer System Effects Data](#).

Length (in.)	Face Velocity (ft. per min) / Pressure Drop (in.w.g.)						
	500	750	1000	1250	1500	1750	2000
36	0.03	0.06	0.10	0.16	0.23	0.32	0.41
60	0.04	0.09	0.16	0.24	0.35	0.48	0.63
84	0.05	0.12	0.21	0.33	0.47	0.64	0.84
108	0.05	0.12	0.21	0.33	0.47	0.64	0.84

Acceptable (0 - 0.35") Caution (>0.35") Pressure Drop may be too high for certain applications

Generated Noise (GN)

@ 5 sq.ft. face area

Length (in.)	Face Velocity (ft. per min)	Octave Band - Hz/Generated Noise (dB re 10 ⁻¹² watts)							
		63	125	250	500	1K	2K	4K	8K
All	- 1250	55	52	49	49	50	50	42	34
	- 750	52	41	40	41	40	33	22	24
	+ 750	51	39	37	37	35	28	21	24
	+ 1250	56	52	48	47	46	46	39	32

GN correction chart at right must be used to correct GN to other face areas. →

Face Area (sq.ft.)	2.5	5	10	20	40	80
dB	-3	0	+3	+6	+9	+12

Cross Section Sizes*

"A" dimension (in.)
 9.5–10.5
 19–21
 38–42
 57–63
 76–84
 95–105
 114–126
 133–147
 152–168
 171–189

"B" dimension ANY SIZE

See [Rectangular Silencer Cross-Section Dimensions](#) to ensure selection matches ductwork dimensions.

RFMB-MV-F7

Rectangular Film MoldBlock
Medium velocity silencer
(<1250 fpm)

How to Specify Example:

37 × **21** **RFMB-MV-F7** × **60**
 ↑ Duct Width ↑ Duct Height ↑ Silencer Model ↑ Silencer Length

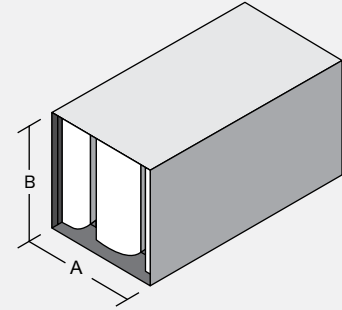

Insertion Loss (IL)

+ : "forward flow" where noise & airflow move in same direction (e.g. supply side)

- : "reverse flow" where noise & airflow move in opposite directions (e.g. return side)

See [Silencer Selection Instructions](#). DIL above 50dB may be limited due to noise flanking around the silencer or along the duct walls. If more than 50dB DIL is required, contact your local Vibro-Acoustics Representative or call **1-800-565-8401**.

Length (in.)	Face Velocity (ft. per min)	Octave Band - Hz/Dynamic Insertion Loss (dB)							
		63	125	250	500	1000	2000	4000	8000
36	- 1250	4	5	11	19	22	20	15	7
	+ 1250	3	4	9	17	21	20	16	7
60	- 1250	7	8	15	26	33	32	22	9
	+ 1250	5	6	13	23	31	33	23	9
84	- 1250	11	11	19	32	43	43	29	10
	+ 1250	8	9	16	29	40	46	31	11
108	- 1250	9	14	26	33	45	43	29	9
	+ 1250	7	11	23	35	47	49	36	13

Pressure Drop (PD)

Pressure drops are reported in accordance with ASTM E477 methods and are based upon **ideal** flow conditions (5 diameters of straight duct on silencer inlet and 10 on outlet). Less than ideal conditions will result in an increase in pressure drop due to System Effects. See [Silencer System Effects Data](#).

Length (in.)	Face Velocity (ft. per min) / Pressure Drop (in.w.g.)						
	500	750	1000	1250	1500	1750	2000
36	0.03	0.06	0.11	0.16	0.24	0.32	0.42
60	0.04	0.09	0.17	0.26	0.37	0.51	0.66
84	0.06	0.13	0.24	0.37	0.53	0.72	0.94
108	0.05	0.12	0.22	0.34	0.49	0.67	0.88

Acceptable (0 - 0.35") Caution (>0.35") Pressure Drop may be too high for certain applications

Generated Noise (GN)

@ 5 sq.ft. face area

Length (in.)	Face Velocity (ft. per min)	Octave Band - Hz/Generated Noise (dB re 10 ⁻¹² watts)							
		63	125	250	500	1K	2K	4K	8K
All	- 1250	55	52	49	49	49	49	41	34
	- 750	51	41	39	41	39	32	22	24
	+ 750	51	39	37	38	35	28	21	24
	+ 1250	56	51	48	47	46	46	39	33

GN correction chart at right must be used to correct GN to other face areas. →

Face Area (sq.ft.)	2.5	5	10	20	40	80
dB	-3	0	+3	+6	+9	+12

Cross Section Sizes*

"A" dimension (in.)
 8.25-9.5
 16.5-19
 33-38
 49.5-57
 66-76
 82.5-95
 99-114
 115.5-133
 132-152
 148.5-171

"B" dimension
 ANY SIZE

See [Rectangular Silencer Cross-Section Dimensions](#) to ensure selection matches ductwork dimensions.

RFMB-MV-F8

Rectangular Film MoldBlock
Medium velocity silencer
(<1250 fpm)

How to Specify Example:

14 X 22 RFMB-MV-F8 X 60
 ↑ Duct Width ↑ Duct Height ↑ Silencer Model ↑ Silencer Length

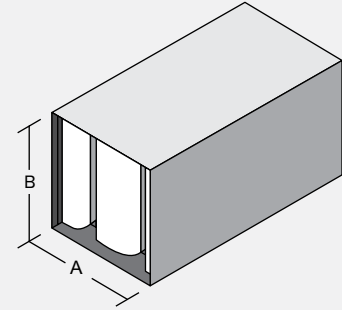

Insertion Loss (IL)

+ : "forward flow" where noise & airflow move in same direction (e.g. supply side)

- : "reverse flow" where noise & airflow move in opposite directions (e.g. return side)

See [Silencer Selection Instructions](#). DIL above 50dB may be limited due to noise flanking around the silencer or along the duct walls. If more than 50dB DIL is required, contact your local Vibro-Acoustics Representative or call **1-800-565-8401**.

Length (in.)	Face Velocity (ft. per min)	Octave Band - Hz/Dynamic Insertion Loss (dB)							
		63	125	250	500	1000	2000	4000	8000
36	- 1250	4	6	10	17	20	21	20	12
	+ 1250	3	4	8	16	19	20	21	11
60	- 1250	5	8	14	25	32	29	25	11
	+ 1250	4	6	12	23	31	31	27	11
84	- 1250	7	10	19	33	44	38	30	11
	+ 1250	5	8	16	31	43	41	33	12
108	- 1250	9	12	24	39	49	48	36	12
	+ 1250	6	10	20	39	49	52	40	14

Pressure Drop (PD)

Pressure drops are reported in accordance with ASTM E477 methods and are based upon **ideal** flow conditions (5 diameters of straight duct on silencer inlet and 10 on outlet). Less than ideal conditions will result in an increase in pressure drop due to System Effects. See [Silencer System Effects Data](#).

Length (in.)	Face Velocity (ft. per min) / Pressure Drop (in.w.g.)						
	500	750	1000	1250	1500	1750	2000
36	0.04	0.09	0.16	0.24	0.35	0.47	0.62
60	0.05	0.12	0.21	0.33	0.47	0.64	0.83
84	0.07	0.15	0.26	0.41	0.59	0.80	1.05
108	0.08	0.18	0.32	0.49	0.71	0.97	1.26

Acceptable (0 - 0.35") Caution (>0.35") Pressure Drop may be too high for certain applications

Generated Noise (GN)

@ 5 sq.ft. face area

Length (in.)	Face Velocity (ft. per min)	Octave Band - Hz/Generated Noise (dB re 10 ⁻¹² watts)							
		63	125	250	500	1K	2K	4K	8K
All	- 1250	55	52	49	49	49	49	41	34
	- 750	51	41	49	41	39	32	22	24
	+ 750	51	39	37	38	35	28	21	24
	+ 1250	56	52	48	47	46	46	39	33

GN correction chart at right must be used to correct GN to other face areas. →

Face Area (sq.ft.)	2.5	5	10	20	40	80
dB	-3	0	+3	+6	+9	+12

Cross Section Sizes*

"A" dimension (in.)
 6.75-8.25
 13.5-16.5
 27-33
 40.5-49.5
 54-66
 67.5-82.5
 81-99
 94.5-115.5
 108-132
 121.5-148.5

"B" dimension
 ANY SIZE

See [Rectangular Silencer Cross-Section Dimensions](#) to ensure selection matches ductwork dimensions.

RFMB-MV-F9

Rectangular Film MoldBlock
Medium velocity silencer
(<1250 fpm)

How to Specify Example:

21 X 21 RFMB-MV-F9 X 60
 ↑ Duct Width ↑ Duct Height ↑ Silencer Model ↑ Silencer Length

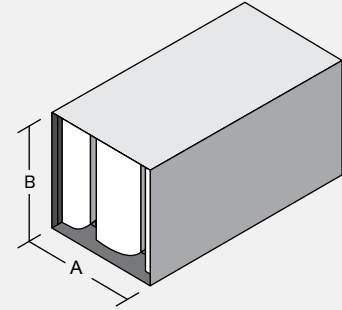

Insertion Loss (IL)

+ : "forward flow" where noise & airflow move in same direction (e.g. supply side)

- : "reverse flow" where noise & airflow move in opposite directions (e.g. return side)

See [Silencer Selection Instructions](#). DIL above 50dB may be limited due to noise flanking around the silencer or along the duct walls. If more than 50dB DIL is required, contact your local Vibro-Acoustics Representative or call **1-800-565-8401**.

Length (in.)	Face Velocity (ft. per min)	Octave Band - Hz/Dynamic Insertion Loss (dB)							
		63	125	250	500	1000	2000	4000	8000
36	- 1250	4	4	9	18	26	24	18	8
	+ 1250	3	3	8	16	25	24	20	9
60	- 1250	7	8	15	27	38	36	30	10
	+ 1250	4	6	12	25	36	37	32	11
84	- 1250	9	11	20	36	50	47	42	13
	+ 1250	6	9	17	33	47	50	44	13
108	- 1250	7	11	21	34	45	44	40	10
	+ 1250	5	9	18	36	49	50	50	15

Pressure Drop (PD)

Pressure drops are reported in accordance with ASTM E477 methods and are based upon **ideal** flow conditions (5 diameters of straight duct on silencer inlet and 10 on outlet). Less than ideal conditions will result in an increase in pressure drop due to System Effects. See [Silencer System Effects Data](#).

Length (in.)	Face Velocity (ft. per min) / Pressure Drop (in.w.g.)						
	500	750	1000	1250	1500	1750	2000
36	0.03	0.06	0.11	0.17	0.25	0.34	0.44
60	0.05	0.11	0.19	0.30	0.43	0.58	0.76
84	0.08	0.17	0.31	0.48	0.70	0.95	1.24
108	0.06	0.14	0.25	0.39	0.56	0.77	1.00

Acceptable (0 - 0.35") Caution (>0.35") Pressure Drop may be too high for certain applications

Generated Noise (GN)

@ 5 sq.ft. face area

Length (in.)	Face Velocity (ft. per min)	Octave Band - Hz/Generated Noise (dB re 10 ⁻¹² watts)							
		63	125	250	500	1K	2K	4K	8K
All	- 1250	57	53	48	48	47	45	39	35
	- 750	50	40	38	41	37	28	21	24
	+ 750	50	40	38	41	37	28	21	24
	+ 1250	57	53	48	48	47	45	39	35

GN correction chart at right must be used to correct GN to other face areas. →

Face Area (sq.ft.)	2.5	5	10	20	40	80
dB	-3	0	+3	+6	+9	+12

Cross Section Sizes*

"A" dimension (in.)
 5-6.75
 10-13.5
 20-27
 30-40.5
 40-54
 50-67.5
 60-81
 70-94.5
 80-108
 90-121.5

"B" dimension
 ANY SIZE

See [Rectangular Silencer Cross-Section Dimensions](#) to ensure selection matches ductwork dimensions.