

# Data Center Southwestern Ontario

## SCOPE & SUCCESS

Vibro-Acoustics has provided over **285 silencer solutions and 280 vibration isolation systems** for the data center, meeting the required noise criteria in the occupied space and at the neighboring property lines.

### HIGHLIGHTS

- > Levels met at property line
- > Performance guarantee offered
- > System designed with ultra-low pressure drop
- > Integrated systems approach used at design stage

**Improved Energy Efficiency**  
★★★★

**Project Risk Minimization**  
★★★★★

**Best Practice Operation**  
★★★★★

**Noise Criteria**  
★★★★★

## OVERVIEW

The data center, located in Southwestern Ontario, is a high-level security building that stores important records.

To maintain the vast amount of information, the 220,000 ft<sup>2</sup> building uses an integrated emergency backup power system. The system consists of 12 diesel generators, which can provide a total of 2,030,400 KW of electrical energy, and two load cells for generator exercising. To cool the generators, a series of 12 propeller fans were installed into a 40,000 ft<sup>3</sup> air intake plenum. These fans can move over 1,139,873 CFM of air through the generator room.

## ⚠ CHALLENGES

**THE SOUND PRESSURE LEVEL** created by the combination of the generators and propeller fans is around 120 dBA (high enough to damage the unprotected human ear). A substantial amount of insertion loss (IL) was required to meet the noise criteria (local code, NPC-205) of 50 dBA (day) and 45 dBA (night) at the closest property line, which is 150 ft. from the generator room. In addition, the static pressure loss through the silencers had to be kept very low in order to keep the size of the fan motors to a minimum.

Lastly, vibration traveling through the exhaust mufflers and into the roof structure had to be addressed. The mufflers, manufactured with stainless steel, expand and contract as the generators turn on and off. The vibration isolation solution had to accommodate this thermal growth as well as isolate the system.

 **SOLUTION**

**Vibro-Acoustics addressed all noise and vibration control issues and helped reduce operating costs.**

**VIBRO-ACOUSTICS USED THE “SYSTEMS APPROACH”** early in the design phase to complete a full vibration and acoustical analysis of the project. The integrated noise control solution, which resulted in a pressure loss of only 0.15” wg and a dBA level lower than the local code requirement of 45 dBA, helped reduce the building’s operating costs.

For the two load cells located in the generator room, Vibro-Acoustics provided Fit-The-System silencers on the cells for noise attenuation. Forty-eight vibration isolation systems were supplied for the generator sets. SNSN neoprene pads were provided to dampen the vibration traveling through the transmission lines.

For the air intake system, twelve large dissipative rectangular silencers were provided, with a pressure drop of only 0.08” wg. Each silencer was designed for medium velocity air movement at a total flow of 110,000 CFM. For the discharge

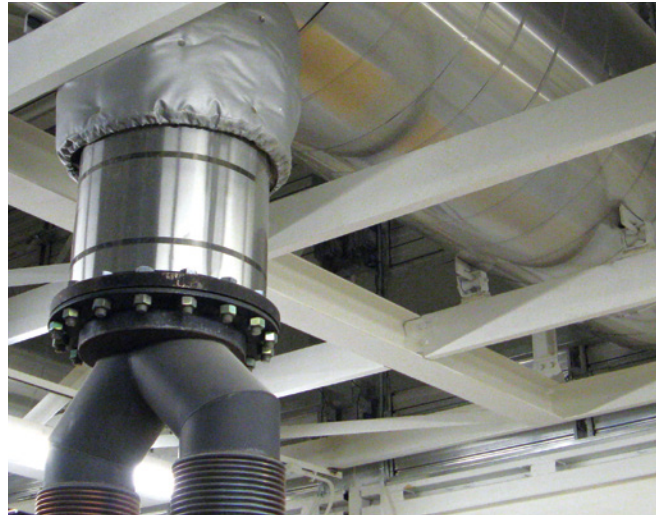

air system, Vibro-Acoustics provided twelve dissipative rectangular silencers with a pressure drop of 0.068” wg at 95,000 CFM.

To address the thermal growth of the exhaust mufflers caused by the operation of the generators, Vibro-Acoustics designed and manufactured a unique solution. The supports on one end of the muffler were fitted with rollers to enable motion for expansion and contraction (Fig. 1).

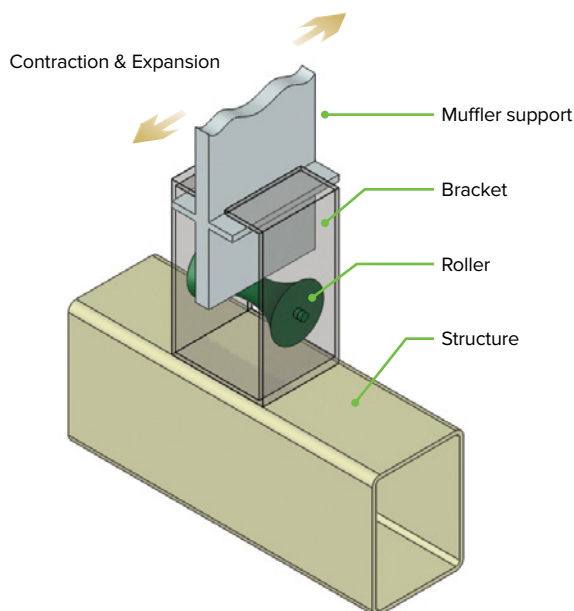

**Fig. 1**  
Muffler support solution

Solution Details								
<b>Intake Silencers</b>	RD-MV-F4							
<b>Intake Silencers - Air Flow</b>	-110,000 CFM							
<b>Intake Silencers - PD</b>	0.08” wg							
<b>Intake Silencers - IL</b>	<b>63</b>	<b>125</b>	<b>250</b>	<b>500</b>	<b>1k</b>	<b>2k</b>	<b>4k</b>	<b>8k</b>
	11	15	25	43	41	22	17	12
<b>Load Cell Silencers</b>	RD-MV-F4							
<b>Load Cell Silencers – Air Flow</b>	78,000 CFM							
<b>Load Cell Silencers – PD</b>	0.0001” wg							
<b>Load Cell Silencers – IL</b>	<b>63</b>	<b>125</b>	<b>250</b>	<b>500</b>	<b>1k</b>	<b>2k</b>	<b>4k</b>	<b>8k</b>
	2	5	8	11	7	6	5	5
<b>Discharge Silencers</b>	RD-LV-FB							
<b>Discharge Silencers – Air Flow</b>	95,000 CFM							
<b>Discharge Silencers – PD</b>	0.068” wg							
<b>Discharge Silencers – IL</b>	<b>63</b>	<b>125</b>	<b>250</b>	<b>500</b>	<b>1k</b>	<b>2k</b>	<b>4k</b>	<b>8k</b>
	9	15	25	28	34	24	18	15
<b>Vibration Isolation</b>	SNSN Pads / Custom rollers to accommodate thermal expansion							